



# MODEL WPAK HYDRONIC COIL INSTALLATION INSTRUCTIONS

## General

The SpacePak Model WPAK Hydronic Heating coil is designed for use with the SpacePak Model ESP-E/D/V Fan Coil Units. The unit mounts to the inlet of the Fan Coil Unit and requires installation of a SpacePak return air duct adaptor for D & V-Series units only. E-Series units are factory supplied with a removable, return air panel used in lieu of the adaptor. The coil is equipped with a purge plug to remove air trapped in the piping system and a drain plug to remove the water for maintenance or extended shut downs. The plugs are conveniently located so they can be removed without removing any panels. Use the chart below to match the proper Hydronic Coil with the SpacePak Fan Coil Unit.

Hot Water Coil Model #	BTUH Capacity (Nominal)	Return Air Duct Adaptor* Model #	Fan Coil Unit Model #s
AC-WPAK-60	60,000	AC-WRDA-60	ESP-2430E/D/V
AC-WPAK-90	90,000	AC-WRDA-90	ESP-3642E/D/V
AC-WPAK-120	120,000	AC-WRDA-120	ESP-4860E/D/V

\* Required Accessory for both D & V-Series Fan Coil Units  
E-Series units use the removable, return air panel.

**CAUTION** Air discharge temperatures can exceed 160°F. Do not install this coil in systems that have floor outlets if operating in this temperature range.

## Installation

The HWC coil can be easily installed in the field by one person using the following steps:

- (Recommended) Install an auxiliary drain pan with drain piping under the Hydronic Coil or under both the Fan Coil Unit and the Hydronic Coil as shown in Figure 1. The auxiliary drain pan should extend approximately 2 inches beyond the unit on all sides and be 1½ to 2 inches deep. The drain line should be properly trapped and pitched but do not connect it to the primary condensate drain line.
- Remove the return (flex) duct from the Fan Coil Unit inlet.
- Remove all screws from the return air side of the E-Series units. Includes the screws in return air panel and at end of cabinet.

Remove the top and bottom panel screws on D-Series units.

- Apply adhesive backed foam insulating tape supplied with the coil to the perimeter of the coil frame which will be matched to the Fan Coil Unit. The coil connections should be on the same side of the unit as the primary drain pan line(s).
- Line up the flange holes of the Hydronic Coil with the holes on the unit and replace the screws to mount the coil in place.
- Attach return air panel (or return air adaptor on D-Series) to coil using removed screws as shown in Figure 2.
- Provide support under the coil to remove the load on the mounting screws.
- Reattach the return air (flex) duct. Then tape the connection to prevent air leaks.
- Wrap coil casing and return air duct adaptor with a minimum 1" fiberglass insulation blanket.

FIG. 1 SETTING OF HYDRONIC COIL

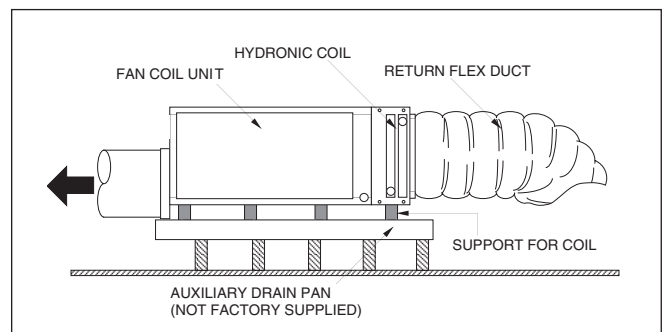
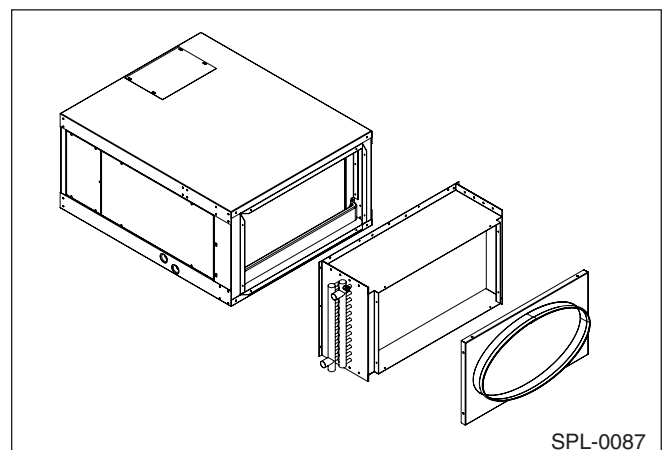

FIG. 2 ATTACHMENT OF HYDRONIC COIL



SPL-0087

## Hot Water Piping

**▲ CAUTION** If the unit is installed in a cold space below 32°F, provisions must be made to prevent damage to the equipment caused by freezing.

All piping must be in accordance with local plumbing codes and regulations.

The hydronic coil may be used in an attic or crawl space but must be protected against possible freeze-up. Use measures such as continuously circulating the water and or draining the coil. See Figure 3 for recommended water piping arrangement.

The inlet and outlet water lines are 7/8 inch OD copper to which connections are made using 7/8 inch sweat fittings.

After the water lines are connected, the piping system should be filled with water. Open the air vent near the top of the coil. Allow the air to escape while filling the system. When a steady stream of water appears tighten the plug.

Insulate the supply and return hot water lines the entire length of run between the boiler and hydronic coil. A nominal wall thickness of 1/2 inch flexible foam rubber closed-cell pipe insulation, suitable for 220°F is recommended.

## Maintenance

As for any heat exchanger, the hydronic coil surface should be cleaned at least once a year. To remove dirt from the fin surface on the inlet side of the coil use a dry soft bristle brush and a vacuum cleaner. Soap and water is not necessary. Also, the air filters should be cleaned regularly.

The air should be purged from the piping system at least once a year.

**FIG. 3 RECOMMENDED WATER PIPING**

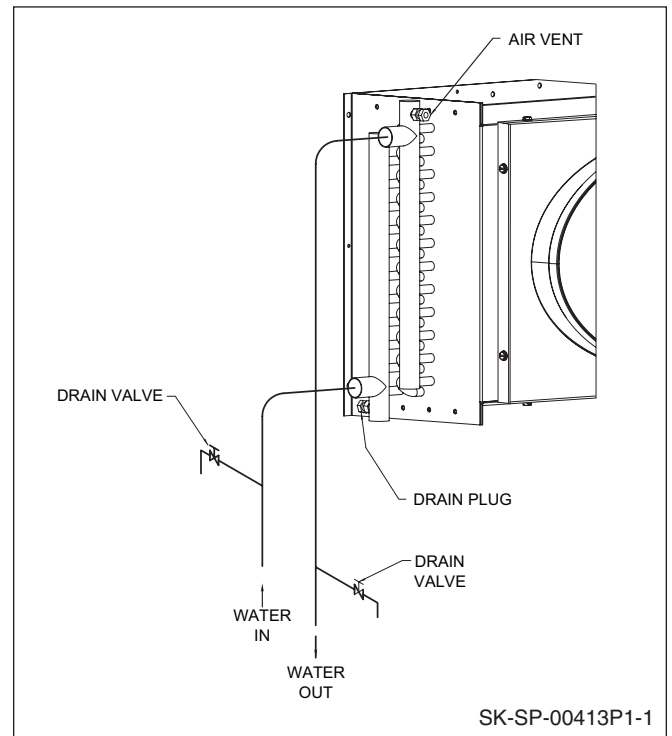

**FIG. 4 DIMENSIONS OF HYDRONIC COILS (inches)**

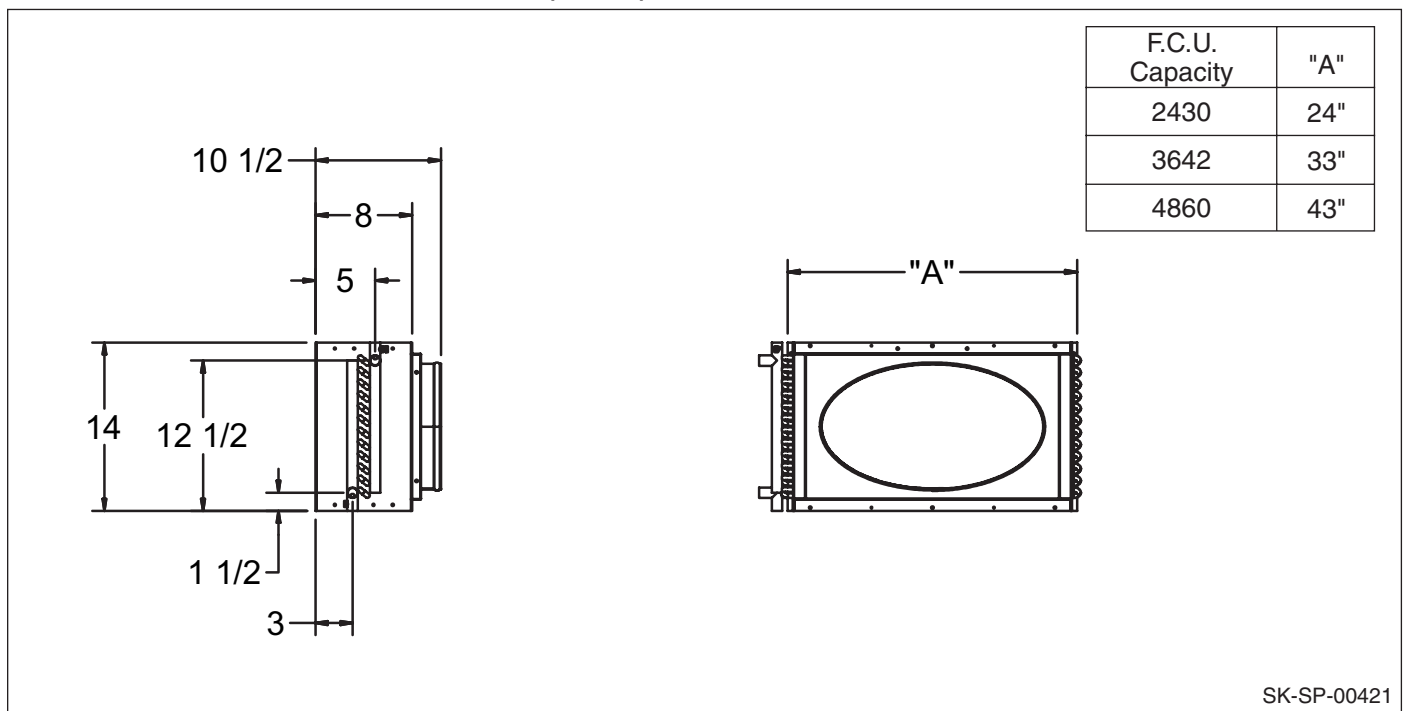

# TYPICAL WIRING FOR A SPACEPAK UNIT WITH A HYDRONIC COIL

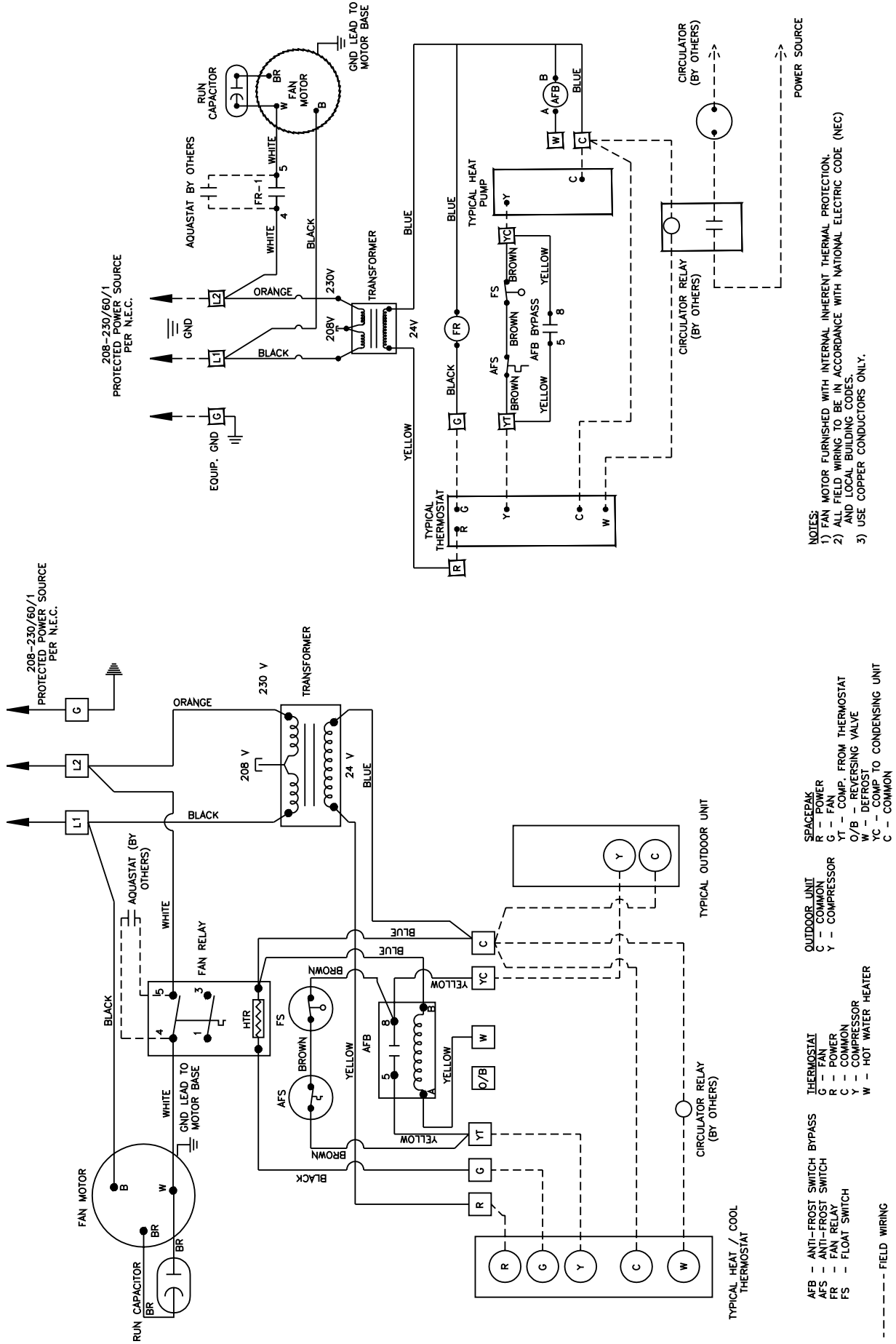

- NOTES:**
- 1) FAN MOTOR FURNISHED WITH INTERNAL INHERENT THERMAL PROTECTION.
  - 2) ALL FIELD WIRING TO BE IN ACCORDANCE WITH NATIONAL ELECTRIC CODE (NEC) AND LOCAL BUILDING CODES.
  - 3) USE COPPER CONDUCTORS ONLY.

SPL-0069-B

- SPACEPAK**  
R - POWER  
G - FAN  
Y - COMP. FROM THERMOSTAT  
O/B - REVERSING VALVE  
W - DEFROST  
YC - COMP TO CONDENSING UNIT  
C - COMMON
- OUTDOOR UNIT**  
C - COMMON  
Y - COMPRESSOR
- THERMOSTAT**  
G - FAN  
R - COMMON  
C - COMPRESSOR  
Y - HOT WATER HEATER  
W - COMMON
- ANTI-FROST SWITCH BYPASS**  
AFB - ANTI-FROST SWITCH  
AFS - ANTI-FROST SWITCH  
FR - FAN RELAY  
FS - FLOAT SWITCH
- WIRING**  
- - - - - FIELD WIRING  
\_\_\_\_\_ FACTORY WIRING

## Hydronic Coil Heating Capacity (MBH)

### AC-WPAK-60

GPM	Entering Water Temperature (F)				
	120	140	160	180	200
2	20.5	30.0	39.1	48.1	57.2
4	25.2	35.6	46.1	56.6	67.1
6	26.6	37.4	48.3	59.2	70.2
8	27.2	38.2	49.3	60.4	71.6
10	27.5	38.7	49.9	61.1	72.3

At 550CFM and 70°F Entering Air Temperature

### AC-WPAK-90

GPM	Entering Water Temperature (F)				
	120	140	160	180	200
2	26.8	39.2	51.6	63.4	75.2
4	36.0	50.8	65.7	80.8	95.8
6	39.0	54.9	70.9	87.0	103.1
8	40.4	56.8	73.3	89.9	106.5
10	41.2	57.9	74.7	91.5	108.4

At 850CFM and 70°F Entering Air Temperature

### AC-WPAK-120

GPM	Entering Water Temperature (F)				
	120	140	160	180	200
2	31.7	46.2	61.2	75.1	89.0
4	45.6	64.2	83.0	102.0	120.9
6	50.6	71.2	92.0	112.9	133.8
8	53.1	74.7	96.4	118.2	140.1
10	54.6	76.7	98.9	121.2	143.6

At 1150CFM and 70°F Entering Air Temperature

### Water Pressure Drop (in feet @ 180°)

GPM	AC-WPAK-60	AC-WPAK-90	AC-WPAK-120
2	0.4	0.4	0.5
4	1.4	1.6	1.7
6	3.0	3.3	3.7
8	5.2	5.7	6.3
10	7.9	8.7	9.6

To calculate Leaving Air Temperature (LAT) use the following formula:

$$LAT = (BTUH / (1.08 \times CFM)) + 70$$

### ⚠ CAUTION

AREAS SHADED IN GRAY CAN EXCEED 160°F LEAVING AIR TEMPERATURE. TO PREVENT INJURY OR DAMAGE, DO NOT INSTALL FLOOR OUTLETS WHEN THE SYSTEM IS OPERATING IN THIS RANGE.

## GLYCOL CORRECTION FACTORS

### Freezing Point

Concentration by volume	Ethylene Glycol	Propylene Glycol
55%	-50F	-40F
50%	-37F	-28F
40%	-14F	-13F
30%	+2F	+4F
20%	+15F	+17F

### Heat Transfer @ 180°F (no change in flow rate)

Solution %	Ethylene Glycol	Propylene Glycol
20%	.96	.97
50%	.87	.90

### Flow Rate Correction (no change in pump curve)

Temperature	Ethylene Glycol	Propylene Glycol
100°F	116%	114%
140°F	115%	112%
180°F	114%	110%

Note: Comparisons are of 50% solution

### Pump Head Correction (with increase in flow)

Temperature	Ethylene Glycol	Propylene Glycol
100°F	149%	141%
140°F	132%	128%
180°F	123%	123%

Note: Comparisons are of 50% solution