

Job Name: _____	Location: _____	Date: _____
Purchaser: _____	Engineer: _____	
Submitted to: _____	For <input type="checkbox"/> Reference <input type="checkbox"/> Approval <input type="checkbox"/> Construction	
System Designation: _____	Schedule No.: _____	

GENERAL FEATURES

- Wall-mounted indoor unit
- Standard Hybrid Catechin Prefilter is included with indoor unit
- Quiet operation
- Choice of fan speeds: Quiet, Low, Medium, High, and Super High; Auto fan speed control also included
- Wireless remote controller is included; PAR-21MAA wired remote controller can be installed as an option
- Indoor unit powered from outdoor unit using A-Control
- Auto restart following a power outage
- Base heater is available as an option
- Limited warranty: five years on parts and defects and seven years on the compressor

OPTIONAL ACCESSORIES
Outdoor Unit

- Base Heater (MAC-640BH-U)
- Drain Socket Assembly (MAC-860DS)

Indoor Unit

- M-NET Control Adapter (MAC-399IF)
- MA Contact Terminal Interface (MAC-397IF)
- Wired Remote Controller (PAR-21MAA; requires MAC-397IF)
- Condensate Pump (230V; SI3100-230)
- Anti-allergy Enzyme Filter (Two pieces per set; MAC-408FT-E)

Cooling*

Rated Capacity 9,000 Btu/h
 Minimum Capacity 3,800 Btu/h
 SEER 21.0 Btu/h/W
 Total Input 660 W

Heating at 47°F*

Rated Capacity 10,900 Btu/h
 Minimum Capacity 4,500 Btu/h
 HSPF 10.0 Btu/h/W
 Total Input 760 W

Heating at 17°F*

Rated Capacity 6,600 Btu/h
 Rated Total Input 700 W
 Maximum Capacity 8,700 Btu/h
 Maximum Total Input 950 W

* Rating Conditions (Cooling) - Indoor: 80°F (27°C) DB, 67°F (19°C) WB; Outdoor: 95°F (35°C) DB, 75°F (24°C) WB.

(Heating at 47°F) - Indoor: 70°F (21°C) DB, 60°F (16°C) WB; Outdoor: 47°F (8°C) DB, 43°F (6°C) WB.
 (Heating at 17°F) - Indoor: 70°F (21°C) DB, 60°F (16°C) WB; Outdoor: 17°F (-8°C) DB, 15°F (-9°C) WB.

Electrical Requirements

Power Supply 208 / 230V, 1-Phase, 60 Hz
 Breaker Size 15 A

Voltage

Indoor - Outdoor S1-S2 AC 208 / 230V
 Indoor - Outdoor S2-S3 DC 12-24V
 Indoor - Remote Controller Wireless

OPERATING RANGE

		Indoor Intake Air Temp.	Outdoor Intake Air Temp.
Cooling	Maximum	90°F (32°C) DB, 73°F (23°C) WB	115°F (46°C) DB
	Minimum	67°F (19°C) DB, 57°F (14°C) WB	14°F (-10°C) DB
Heating	Maximum	80°F (27°C) DB, 67°F (19°C) WB	75°F (24°C) DB, 65°F (18°C) WB
	Minimum	70°F (21°C) DB, 60°F (16°C) WB	-4°F (-20°C) DB, -5°F (-21°C) WB

Indoor Unit

MCA 1 A
 Fan Motor 0.76 F.L.A.
 Airflow (Quiet - Lo - Med - Hi - Super Hi)
 Cooling 145 - 170 - 237 - 321 - 399 Dry CFM
 109 - 134 - 201 - 286 - 364 Wet CFM
 Heating 145 - 170 - 237 - 321 - 406 Dry CFM

Sound Pressure Level (Quiet - Lo - Med - Hi - Super Hi)

Cooling 19 - 22 - 30 - 37 - 43 dB(A)
 Heating 19 - 22 - 30 - 37 - 43 dB(A)

DIMENSIONS	UNIT INCHES / MM
W	31-7/16 / 799
D	9-1/8 / 232
H	11-5/8 / 295

Weight 22 lbs. / 10 kg
 External Finish Munsell No. 1.0Y 9.2 / 0.2
 Field Drainpipe Size O.D. 5/8" / 15.88 mm
 Remote Controller Wireless
 (Optional Wired Remote Controller PAR-21MAA;
 see Data Submittal Sheet)

Outdoor Unit

Compressor DC Inverter-driven
 MCA 12 A
 Fan Motor 0.50 F.L.A.
 Sound Pressure Level
 Cooling 46 dB(A)
 Heating 50 dB(A)

DIMENSIONS	INCHES / MM
W	31-1/2 / 800
D	11-1/4 / 286
H	21-5/8 / 549

Weight 66 lbs. / 30 kg
 External Finish Munsell No. 3Y 7.8 / 1.1

Refrigerant Type R410A
 Refrigerant Pipe Size O.D.
 Gas Side 3/8" / 9.52 mm
 Liquid Side 1/4" / 6.35 mm
 Max. Refrigerant Pipe Length 65 ft. / 20 m
 Max. Refrigerant Pipe Height Difference 40 ft. / 12 m
 Connection Method Flared



DIMENSIONS: MSZ-GE09NA & MUZ-GE09NA

MSZ-GE09NA

Unit: inch

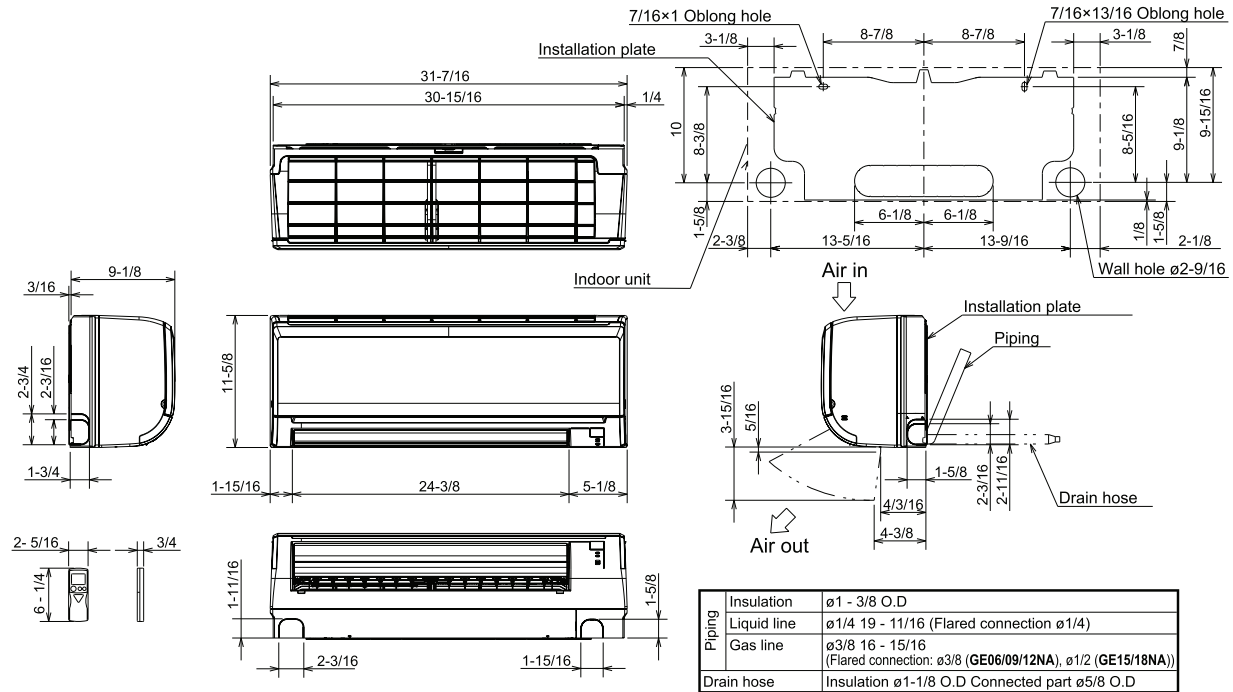

MUZ-GE09NA

Unit: inch

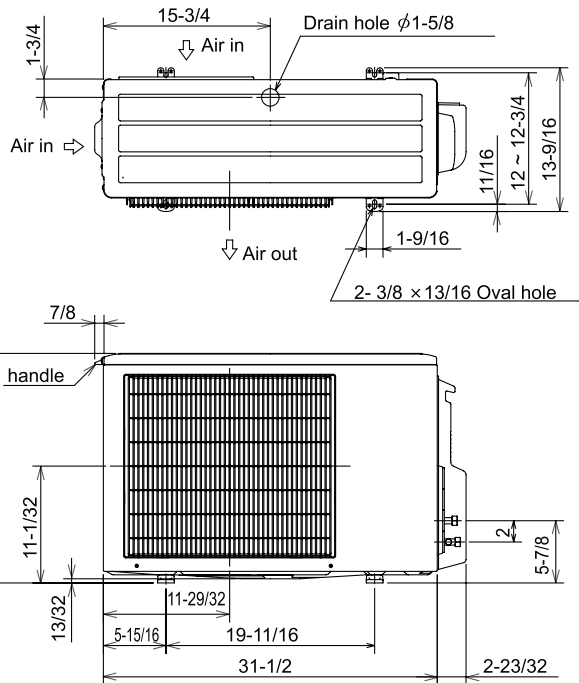

REQUIRED SPACE

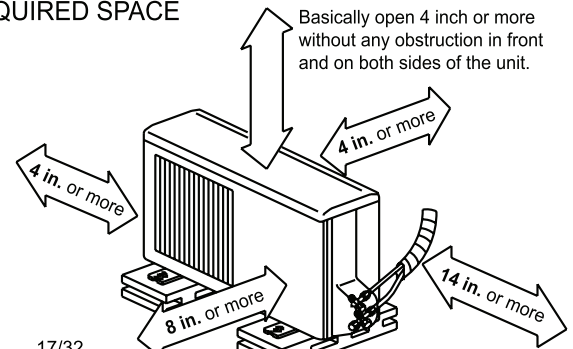

Basically open 4 inch or more without any obstruction in front and on both sides of the unit.

Open two sides of left, right, or rear side.

Liquid pipe :1/4 (flared)
Gas pipe :3/8 (flared) (GE09/12)
 1/2 (flared) (GE15)



HVAC Advanced Products Division
3400 Lawrenceville Suwanee Rd
Suwanee, GA 30024
Tele: 678-376-2900 • Fax: 800-889-9904
Toll Free: 800-433-4822 (#3)
www.mehvac.com
Specifications are subject to change without notice.

