

# **Air-Conditioners**

**PUZ-A·NHA, PUZ-A·NHA-BS**

**PUY-A·NHA, PUY-A·NHA-BS**

## **INSTALLATION MANUAL**

For safe and correct use, read this manual and the indoor unit installation manual thoroughly before installing the air-conditioner unit.

**FOR INSTALLER**

## **MANUAL DE INSTALACIÓN**

Para un uso correcto y seguro, lea detalladamente este manual y el manual de instalación de la unidad interior antes de instalar la unidad de aire acondicionado.

**PARA EL INSTALADOR**

**English**

**Español**

# Contents

1. Safety precautions .....	2	6. Electrical work .....	7
2. Installation location .....	3	7. Test run .....	9
3. Installing the outdoor unit .....	4	8. Special Functions .....	10
4. Installing the refrigerant piping .....	5	9. System control (Fig. 9-1) .....	10
5. Drainage piping work .....	7		

## 1. Safety precautions

- ▶ Before installing the unit, make sure you read all the “Safety precautions”.
- ▶ Please report to or take consent by the supply authority before connection to the system.

**⚠ Warning:**  
Describes precautions that must be observed to prevent danger of injury or death to the user.

**⚠ Caution:**  
Describes precautions that must be observed to prevent damage to the unit.

- ⚠ Warning:**
- The unit must not be installed by the user. Ask a dealer or an authorized technician to install the unit. If the unit is installed incorrectly, water leakage, electric shock, or fire may result.
  - For installation work, follow the instructions in the Installation Manual and use tools and pipe components specifically made for use with R410A refrigerant. The R410A refrigerant in the HFC system is pressurized 1.6 times the pressure of usual refrigerants. If pipe components not designed for R410A refrigerant are used and the unit is not installed correctly, the pipes may burst and cause damage or injuries. In addition, water leakage, electric shock, or fire may result.
  - The unit must be installed according to the instructions in order to minimize the risk of damage from earthquakes, typhoons, or strong winds. An incorrectly installed unit may fall down and cause damage or injuries.
  - The unit must be securely installed on a structure that can sustain its weight. If the unit is mounted on an unstable structure, it may fall down and cause damage or injuries.
  - If the air conditioner is installed in a small room, measures must be taken to prevent the refrigerant concentration in the room from exceeding the safety limit in the event of refrigerant leakage. Consult a dealer regarding the appropriate measures to prevent the allowable concentration from being exceeded. Should the refrigerant leak and cause the concentration limit to be exceeded, hazards due to lack of oxygen in the room may result.
  - Ventilate the room if refrigerant leaks during operation. If refrigerant comes into contact with a flame, poisonous gases will be released.
  - All electric work must be performed by a qualified technician according to local regulations and the instructions given in this manual. The units must be powered by dedicated power lines and the correct voltage and circuit breakers must be used. Power lines with insufficient capacity or incorrect electrical work may result in electric shock or fire.

After installation work has been completed, explain the “Safety Precautions,” use, and maintenance of the unit to the customer according to the information in the Operation Manual and perform the test run to ensure normal operation. Both the Installation Manual and Operation Manual must be given to the user for keeping. These manuals must be passed on to subsequent users.

**⚡** : Indicates a part which must be grounded.

**⚠ Warning:**  
Carefully read the labels affixed to the main unit.

- Use C1220 copper phosphorus, for copper and copper alloy seamless pipes, to connect the refrigerant pipes. If the pipes are not connected correctly, the unit will not be properly grounded and electric shock may result.
- Use only specified cables for wiring. The connections must be made securely without tension on the terminals. If the cables are connected or installed incorrectly, overheating or fire may result.
- The terminal block cover panel of the outdoor unit must be firmly attached. If the cover panel is mounted incorrectly and dust and moisture enter the unit, electric shock or fire may result.
- When installing or moving the air conditioner, use only the specified refrigerant (R410A) to charge the refrigerant lines. Do not mix it with any other refrigerant and do not allow air to remain in the lines. Air enclosed in the lines can cause pressure peaks resulting in a rupture and other hazards.
- Use only accessories authorized by Mitsubishi Electric and ask a dealer or an authorized technician to install them. If accessories are incorrectly installed, water leakage, electric shock, or fire may result.
- Do not alter the unit. Consult a dealer for repairs. If alterations or repairs are not performed correctly, water leakage, electric shock, or fire may result.
- The user should never attempt to repair the unit or transfer it to another location. If the unit is installed incorrectly, water leakage, electric shock, or fire may result. If the air conditioner must be repaired or moved, ask a dealer or an authorized technician.
- After installation has been completed, check for refrigerant leaks. If refrigerant leaks into the room and comes into contact with the flame of a heater or portable cooking range, poisonous gases will be released.

### 1.1. Before installation

- ⚠ Caution:**
- Do not use the unit in an unusual environment. If the air conditioner is installed in areas exposed to steam, volatile oil (including machine oil), or sulfuric gas, areas exposed to high salt content such as the seaside, or areas where the unit will be covered by snow, the performance can be significantly reduced and the internal parts can be damaged.
  - Do not install the unit where combustible gases may leak, be produced, flow, or accumulate. If combustible gas accumulates around the unit, fire or explosion may result.
  - The outdoor unit produces condensation during the heating operation. Make sure to provide drainage around the outdoor unit if such condensation is likely to cause damage.

- When installing the unit in a hospital or communications office, be prepared for noise and electronic interference. Inverters, home appliances, high-frequency medical equipment, and radio communications equipment can cause the air conditioner to malfunction or breakdown. The air conditioner may also affect medical equipment, disturbing medical care, and communications equipment, harming the screen display quality.

### 1.2. Before installation (relocation)

- ⚠ Caution:**
- Be extremely careful when transporting the units. Two or more persons are needed to handle the unit, as it weighs 20 kg, 44 lbs or more. Do not grasp the packaging bands. Wear protective gloves to remove the unit from the packaging and to move it, as you can injure your hands on the fins or other parts.
  - Be sure to safely dispose of the packaging materials. Packaging materials, such as nails and other metal or wooden parts may cause stabs or other injuries.

- The base and attachments of the outdoor unit must be periodically checked for looseness, cracks or other damage. If such defects are left uncorrected, the unit may fall down and cause damage or injuries.
- Do not clean the air conditioner unit with water. Electric shock may result.
- Tighten all flare nuts to specification using a torque wrench. If tightened too much, the flare nut can break after an extended period and refrigerant can leak out.

# 1. Safety precautions

## 1.3. Before electric work

**⚠ Caution:**

- Be sure to install circuit breakers. If not installed, electric shock may result.
- For the power lines, use standard cables of sufficient capacity. Otherwise, a short circuit, overheating, or fire may result.
- When installing the power lines, do not apply tension to the cables. If the connections are loosened, the cables can snap or break and overheating or fire may result.

- Be sure to ground the unit. Do not connect the ground wire to gas or water pipes, lighting rods, or telephone grounding lines. If the unit is not properly grounded, electric shock may result.
- Use circuit breakers (ground fault interrupter, isolating switch (+B fuse), and molded case circuit breaker) with the specified capacity. If the circuit breaker capacity is larger than the specified capacity, breakdown or fire may result.

## 1.4. Before starting the test run

**⚠ Caution:**

- Turn on the main power switch more than 12 hours before starting operation. Starting operation just after turning on the power switch can severely damage the internal parts. Keep the main power switch turned on during the operation season.
- Before starting operation, check that all panels, guards and other protective parts are correctly installed. Rotating, hot, or high voltage parts can cause injuries.
- Do not touch any switch with wet hands. Electric shock may result.

- Do not touch the refrigerant pipes with bare hands during operation. The refrigerant pipes are hot or cold depending on the condition of the flowing refrigerant. If you touch the pipes, burns or frostbite may result.
- After stopping operation, be sure to wait at least five minutes before turning off the main power switch. Otherwise, water leakage or breakdown may result.

## 1.5. Using R410A refrigerant air conditioners

**⚠ Caution:**

- Use C1220 copper phosphorus, for copper and copper alloy seamless pipes, to connect the refrigerant pipes. Make sure the insides of the pipes are clean and do not contain any harmful contaminants such as sulfuric compounds, oxidants, debris, or dust. Use pipes with the specified thickness. (Refer to page 5) Note the following if reusing existing pipes that carried R22 refrigerant.
  - Replace the existing flare nuts and flare the flared sections again.
  - Do not use thin pipes. (Refer to page 5)
- Store the pipes to be used during installation indoors and keep both ends of the pipes sealed until just before brazing. (Leave elbow joints, etc. in their packaging.) If dust, debris, or moisture enters the refrigerant lines, oil deterioration or compressor breakdown may result.
- Use ester oil, ether oil, alkylbenzene oil (small amount) as the refrigeration oil applied to the flared sections. If mineral oil is mixed in the refrigeration oil, oil deterioration may result.

- Do not use refrigerant other than R410A refrigerant. If another refrigerant is used, the chlorine will cause the oil to deteriorate.
- Use the following tools specifically designed for use with R410A refrigerant. The following tools are necessary to use R410A refrigerant. Contact your nearest dealer for any questions.

Tools (for R410A)	
Gauge manifold	Flare tool
Charge hose	Size adjustment gauge
Gas leak detector	Vacuum pump adapter
Torque wrench	Electronic refrigerant charging scale

- Be sure to use the correct tools. If dust, debris, or moisture enters the refrigerant lines, refrigeration oil deterioration may result.
- Do not use a charging cylinder. If a charging cylinder is used, the composition of the refrigerant will change and the efficiency will be lowered.

# 2. Installation location

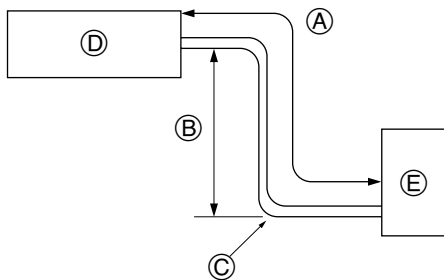

Fig. 2-1

## 2.1. Refrigerant pipe (Fig. 2-1)

- ▶ Check that the difference between the heights of the indoor and outdoor units, the length of refrigerant pipe, and the number of bends in the pipe are within the limits shown below.

Models	Ⓐ Pipe length (one way)	Ⓑ Height difference	Ⓒ Number of bends (one way)
A12, A18	Max. 30 m, 100 ft	Max. 30 m, 100 ft	Max. 15
A24, A30, A36, A42	Max. 50 m, 165 ft	Max. 30 m, 100 ft	Max. 15

- Height difference limitations are binding regardless of which unit, indoor or outdoor, is positioned higher.

- Ⓓ Indoor unit
- Ⓔ Outdoor unit

■ A12, A18 (inch)      ■ A24, A30, A36, A42 (inch)

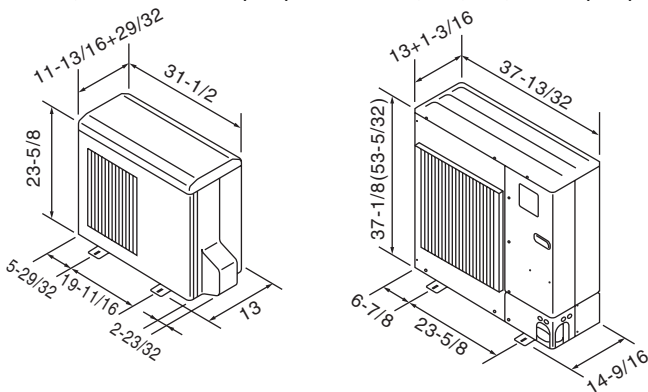

Fig. 2-2

## 2.2. Choosing the outdoor unit installation location

- Avoid locations exposed to direct sunlight or other sources of heat.
- Select a location from which noise emitted by the unit will not inconvenience neighbors.
- Select a location permitting easy wiring and pipe access to the power source and indoor unit.
- Avoid locations where combustible gases may leak, be produced, flow, or accumulate.
- Note that water may drain from the unit during operation.
- Select a level location that can bear the weight and vibration of the unit.
- Avoid locations where the unit can be covered by snow. In areas where heavy snow fall is anticipated, special precautions such as raising the installation location or installing a hood on the air intake must be taken to prevent the snow from blocking the air intake or blowing directly against it. This can reduce the airflow and a malfunction may result.
- Avoid locations exposed to oil, steam, or sulfuric gas.
- Use the transportation handles of the outdoor unit to transport the unit. If the unit is carried from the bottom, hands or fingers may be pinched.

## 2.3. Outline dimensions (Outdoor unit) (Fig. 2-2)

The figure in parenthesis is for A42 model.

## 2. Installation location

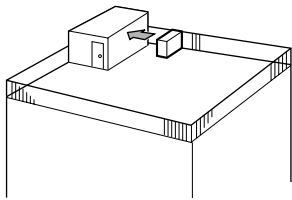

Fig. 2-3

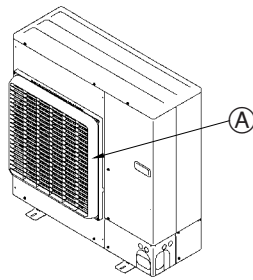

Fig. 2-4

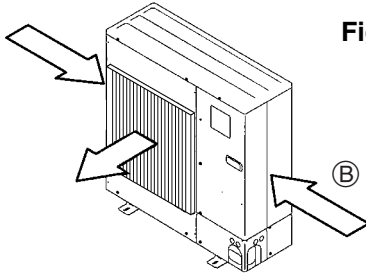

Fig. 2-5

### 2.4. Ventilation and service space

#### 2.4.1. Windy location installation

When installing the outdoor unit on a rooftop or other location unprotected from the wind, situate the air outlet of the unit so that it is not directly exposed to strong winds. Strong wind entering the air outlet may impede the normal airflow and a malfunction may result.

The following shows three examples of precautions against strong winds.

- ① Face the air outlet towards the nearest available wall about 50 cm, 19-11/16 inch away from the wall. (Fig. 2-3)
- ② Install an optional air outlet guide and air guide if the unit is installed in a location where strong winds from a typhoon, etc. may directly enter the air outlet. (Fig. 2-4)
  - Ⓐ Air outlet guide
- ③ Position the unit so that the air outlet blows perpendicularly to the seasonal wind direction, if possible. (Fig. 2-5)
  - Ⓑ Wind direction

#### 2.4.2. When installing a single outdoor unit (Refer to the last page)

Minimum dimensions are as follows, except for Max., meaning Maximum dimensions, indicated.

The figures in parentheses are for A42 models.

Refer to the figures for each case.

- ① Obstacles at rear only (Fig. 2-6)
- ② Obstacles at rear and above only (Fig. 2-7)
- ③ Obstacles at rear and sides only (Fig. 2-8)
  - \* 350 mm, 13-25/32 inch for A12, A18
- ④ Obstacles at front only (Fig. 2-9)
  - \* When using an optional air outlet guide, the clearance for A42 models is 500 mm, 19-11/16 inch or more.
- ⑤ Obstacles at front and rear only (Fig. 2-10)
  - \* When using an optional air outlet guide, the clearance for A42 models is 500 mm, 19-11/16 inch or more.
- ⑥ Obstacles at rear, sides, and above only (Fig. 2-11)
  - \* 350 for A12, A18
  - Do not install the optional air outlet guides for upward airflow.

#### 2.4.3. When installing multiple outdoor units (Refer to the last page)

Leave 350 mm, 13-25/32 inch for A18 and 10 mm, 13/32 inch for A24-A42 space or more between the units.

- ① Obstacles at rear only (Fig. 2-12)
- ② Obstacles at rear and above only (Fig. 2-13)
  - No more than three units must be installed side by side. In addition, leave space as shown.
  - Do not install the optional air outlet guides for upward airflow.
- ③ Obstacles at front only (Fig. 2-14)
  - \* When using an optional air outlet guide, the clearance for A42 models is 1000 mm, 39-3/8 inch or more.
- ④ Obstacles at front and rear only (Fig. 2-15)
  - \* When using an optional air outlet guide, the clearance for A42 models is 1000 mm, 39-3/8 inch or more.
- ⑤ Single parallel unit arrangement (Fig. 2-16)
  - \* When using an optional air outlet guide installed for upward airflow, the clearance is 500 (1000) mm, 19-11/16 (39-3/8) inch or more.
- ⑥ Multiple parallel unit arrangement (Fig. 2-17)
  - \* When using an optional air outlet guide installed for upward airflow, the clearance is 1000 (1500) mm, 39-3/8 (59-1/16) inch or more.
- ⑦ Stacked unit arrangement (Fig. 2-18)
  - The units can be stacked up to two units high.
  - No more than two stacked units must be installed side by side. In addition, leave space as shown.

## 3. Installing the outdoor unit

- Be sure to install the unit in a sturdy, level surface to prevent rattling noises during operation. (Fig. 3-1)

<Foundation specifications>

Foundation bolt	M10 (3/8")
Thickness of concrete	120 mm, 4-23/32 inch
Length of bolt	70 mm, 2-3/4 inch
Weight-bearing capacity	320 kg, 264 lbs

- Make sure that the length of the foundation bolt is within 30 mm, 1-3/16 inch of the bottom surface of the base.

- Secure the base of the unit firmly with four-M10 foundation bolts in sturdy locations.

#### Installing the outdoor unit

- Do not block the vent. If the vent is blocked, operation will be hindered and breakdown may result.
- In addition to the unit base, use the installation holes on the back of the unit to attach wires, etc., if necessary to install the unit. Use self-tapping screws (ø5 × 15 mm, ø13/16 × 19/32 inch or more) and install on site.

#### ⚠ Warning:

- **The unit must be securely installed on a structure that can sustain its weight. If the unit is mounted on an unstable structure, it may fall down and cause damage or injuries.**
- **The unit must be installed according to the instructions in order to minimize the risk of damage from earthquakes, typhoons, or strong winds. An incorrectly installed unit may fall down and cause damage or injuries.**

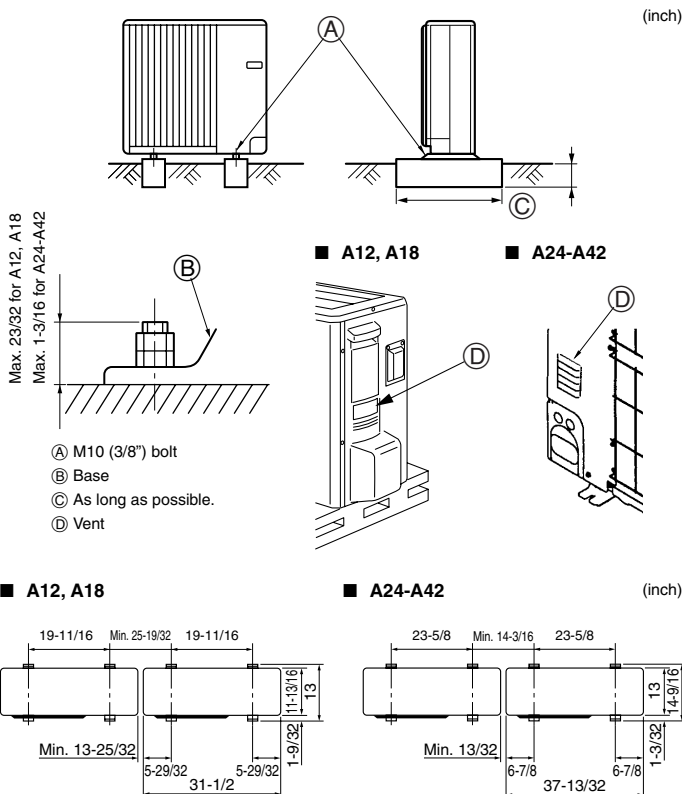

Fig. 3-1

## 4. Installing the refrigerant piping

### 4.1. Precautions for devices that use R410A refrigerant

- Refer to page 3 for precautions not included below on using air conditioners with R410A refrigerant.
- Use ester oil, ether oil, alkylbenzene oil (small amount) as the refrigeration oil applied to the flared sections.
- Use C1220 copper phosphorus, for copper and copper alloy seamless pipes, to connect the refrigerant pipes. Use refrigerant pipes with the thicknesses specified in the table to the below. Make sure the insides of the pipes are clean and do not contain any harmful contaminants such as sulfuric compounds, oxidants, debris, or dust.

#### ⚠ Warning:

When installing or moving the air conditioner, use only the specified refrigerant (R410A) to charge the refrigerant lines. Do not mix it with any other refrigerant and do not allow air to remain in the lines. Air enclosed in the lines can cause pressure peaks resulting in a rupture and other hazards.

	A12, A18	A24-A42
Liquid pipe	ø6.35 mm, 1/4inch thickness 0.8 mm, 1/32 inch	ø9.52 mm, 3/8 inch thickness 0.8 mm, 1/32 inch
Gas pipe	ø12.7 mm, 1/2 inch thickness 0.8 mm, 1/32 inch	ø15.88 mm, 5/8 inch thickness 1.0 mm, 3/64 inch

- Do not use pipes thinner than those specified above.

### 4.2. Connecting pipes (Fig. 4-1)

- When commercially available copper pipes are used, wrap liquid and gas pipes with commercially available insulation materials (heat-resistant to 100 °C, 212 °F or more, thickness of 12 mm, 1/2 inch or more).
- The indoor parts of the drain pipe should be wrapped with polyethylene foam insulation materials (specific gravity of 0.03, thickness of 9 mm, 23/64 inch or more).
- Apply thin layer of refrigerant oil to pipe and joint seating surface before tightening flare nut. (A)
- Use two wrenches to tighten piping connections. (B)
- Use leak detector or soapy water to check for gas leaks after connections are completed.
- Apply refrigerating machine oil over the entire flare seat surface. (C)
- Use the flare nuts for the following pipe size. (D)

	A12, A18	A24, A42
Gas side	Pipe size (mm, inch) ø12.7, 1/2"	ø15.88, 5/8"
Liquid side	Pipe size (mm, inch) ø6.35, 1/4"	ø9.52, 3/8"

\*1: The flare nut is attached to its pipe.

\*2: The flare nut is in the outdoor unit accessory.

Do not use the flare nut attached. If it is used, a gas leakage or even a pipe extraction may occur.

- When bending the pipes, be careful not to break them. Bend radii of 100 mm, 3-15/16 inch to 150 mm, 5-27/32 inch are sufficient.
- Make sure the pipes do not contact the compressor. Abnormal noise or vibration may result.

① Pipes must be connected starting from the indoor unit.

Flare nuts must be tightened with a torque wrench.

② Flare the liquid pipes and gas pipes and apply a thin layer of refrigeration oil (Applied on site).

### 4.3. Refrigerant piping (Fig. 4-3)

#### ■ For A12, A18

Remove the service panel (D) (one screw).

#### ■ For A24-A42

Remove the service panel (D) (three screws) and the front piping cover (A) (two screws) and rear piping cover (B) (two screws).

- Perform refrigerant piping connections for the indoor/outdoor unit when the outdoor unit's stop valve is completely closed.
- Vacuum-purge air from the indoor unit and the connection piping.
- After connecting the refrigerant pipes, check the connected pipes and the indoor unit for gas leaks. (Refer to 4.4 Refrigerant pipe airtight testing method)
- Vacuumize the refrigerant lines through the service port of the liquid stop valve and then open the stop valves completely (for both the liquid and gas stop valves). This will completely connect the refrigerant lines of the indoor and outdoor units.
  - If the stop valves are left closed and the unit is operated, the compressor and control valves will be damaged.
  - Use a leak detector or soapy water to check for gas leaks at the pipe connection sections of the outdoor unit.
  - Do not use the refrigerant from the unit to purge air from the refrigerant lines.
  - After the valve work is completed, tighten the valve caps to the correct torque: 20 to 25 N·m, 14 to 18 ft·lbs (200 to 250 kgf·cm). Failure to replace and tighten the caps may result in refrigerant leakage. In addition, do not damage the insides of the valve caps as they act as a seal to prevent refrigerant leakage.
- Use sealant to seal the ends of the thermal insulation around the pipe connection sections to prevent water from entering the thermal insulation.

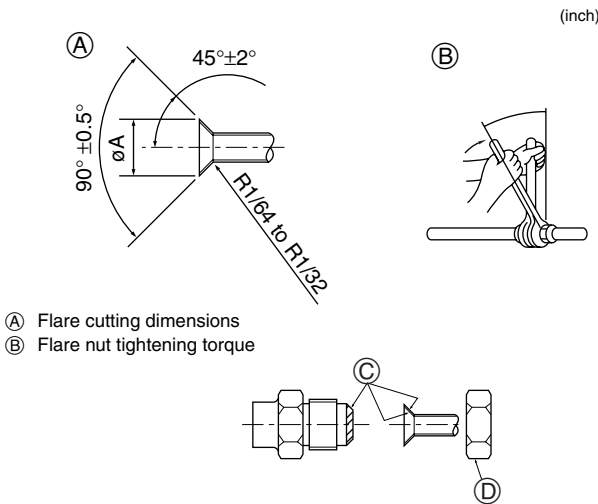

Fig. 4-1

(A) (Fig. 4-1)

Copper pipe O.D.		Flare dimensions øA dimensions	
(mm)	(inch)	(mm)	(inch)
ø6.35	1/4"	8.7 - 9.1	11/32 - 23/64
ø9.52	3/8"	12.8 - 13.2	1/2 - 33/64
ø12.7	1/2"	16.2 - 16.6	41/64 - 21/32
ø15.88	5/8"	19.3 - 19.7	49/64 - 25/32

(B) (Fig. 4-1)

Copper pipe O.D.		Flare nut O.D.		Tightening torque	
(mm)	(inch)	(mm)	(inch)	(N·m)	(ft·lbs)
ø6.35	1/4"	17	43/64	14 - 18	10 - 13
ø9.52	3/8"	22	7/8	34 - 42	25 - 30
ø12.7	1/2"	26	1 - 3/64	49 - 61	35 - 44
ø15.88	5/8"	29	1 - 9/64	68 - 82	49 - 59

#### ■ A12, A18

#### ■ A24-A42

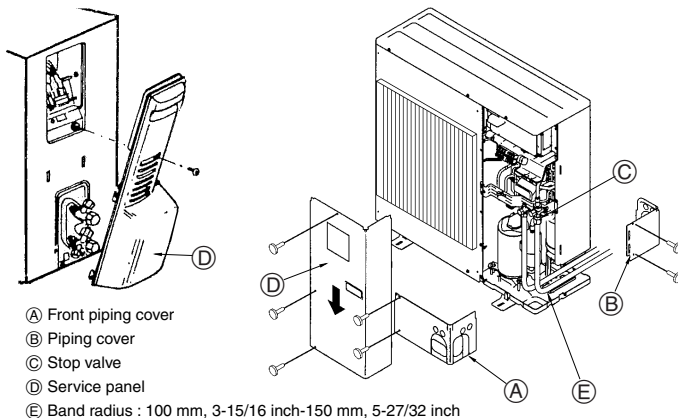

Fig. 4-3

## 4. Installing the refrigerant piping

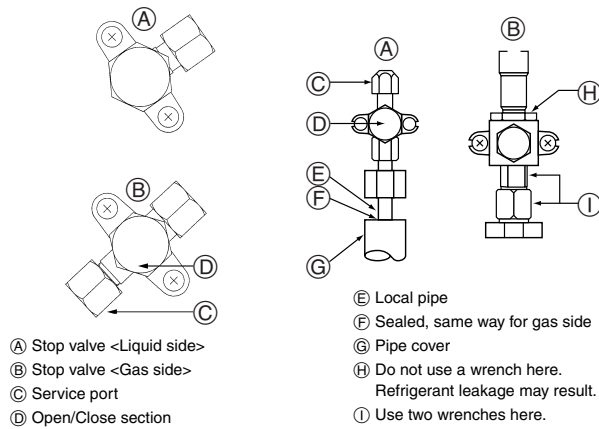

Fig. 4-4

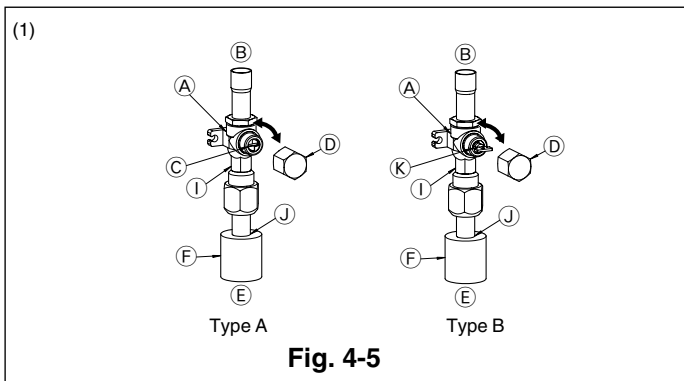

Fig. 4-5

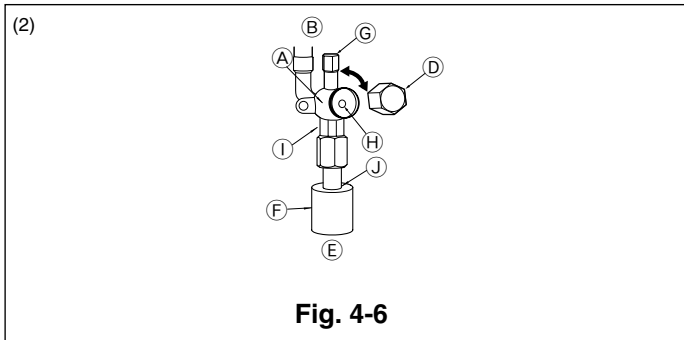

Fig. 4-6

### 4.4. Refrigerant pipe airtight testing method

- (1) Connect the testing tools.
  - Make sure the stop valves (A) (B) are closed and do not open them.
  - Add pressure to the refrigerant lines through the service port (C) of the liquid stop valve (D).
- (2) Do not add pressure to the specified pressure all at once; add pressure little by little.
  - ① Pressurize to 0.5 MPa (5 kgf/cm<sup>2</sup>G), wait five minutes, and make sure the pressure does not decrease.
  - ② Pressurize to 1.5 MPa (15 kgf/cm<sup>2</sup>G), wait five minutes, and make sure the pressure does not decrease.
  - ③ Pressurize to 4.15 MPa (41.5 kgf/cm<sup>2</sup>G) and measure the surrounding temperature and refrigerant pressure.
- (3) If the specified pressure holds for about one day and does not decrease, the pipes have passed the test and there are no leaks.
  - If the surrounding temperature changes by 1 °C, the pressure will change by about 0.03 MPa (0.3 kgf/cm<sup>2</sup>G). Make the necessary corrections.
- (4) If the pressure decreases in steps (2) or (3), there is a gas leak. Look for the source of the gas leak.

### 4.5. Stop valve opening method

- (1) Gas side of A24-A42 (Fig. 4-5)

Type A

- ① Remove the cap, then turn one-quarter rotation counter-clockwise with a flat-bladed screwdriver to complete open.
- ② Check that the valves are fully open, then return the cap to its original state and tighten it down.

Type B

- ① Remove the cap, pull the handle toward you and rotate 1/4 turn in a counterclockwise direction to open.
- ② Make sure that the stop valve is open completely, push in the handle and rotate the cap back to its original position.

- (2) Liquid side of A24-A42 and Gas/Liquid side of A12, A18 (Fig. 4-6)

- ① Remove the cap and turn the valve rod counterclockwise as far as it will go with the use of a 4 mm hexagonal wrench. Stop turning when it hits the stopper. (ø6.35, 1/4 inch: Approximately 4.5 revolutions) (ø9.52, 3/8 inch: Approximately 10 revolutions)
- ② Make sure that the stop valve is open completely, push in the handle and rotate the cap back to its original position.

- (A) Valve
- (B) Unit side
- (C) Operation section
- (D) Cap
- (E) Local pipe side
- (F) Pipe cover
- (G) Service port
- (H) Wrench hole
- (I) Double spanner section  
(Do not apply a spanner other than to this section. Doing so would cause coolant leaks.)
- (J) Seal section  
(Seal the end of the heat insulation material at the pipe connection section with whatever seal material you have on hand so that water does not infiltrate the heat insulation material.)
- (K) Handle

Refrigerant pipes are protectively wrapped for A24-A42

- The pipes can be protectively wrapped up to a diameter of ø90 mm, 3-35/64 inch before or after connecting the pipes. Cut out the knockout in the pipe cover following the groove and wrap the pipes.

Pipe inlet gap for A24-A42

- Use putty or sealant to seal the pipe inlet around the pipes so that no gaps remain. (If the gaps are not closed, noise may be emitted or water and dust will enter the unit and breakdown may result.)

### 4.6. Addition of refrigerant

- Additional charging is not necessary if the pipe length does not exceed 20 m, 70 ft for A12-A36, 30 m 100 ft for A42.
- If the pipe length exceeds the specified length above, charge the unit with additional R410A refrigerant according to the permitted pipe lengths in the chart below.
  - \* When the unit is stopped, charge the unit with the additional refrigerant through the liquid stop valve after the pipe extensions and indoor unit have been vacuumized.
  - When the unit is operating, add refrigerant to the gas check valve using a safety charger. Do not add liquid refrigerant directly to the check valve.

\* After charging the unit with refrigerant, note the added refrigerant amount on the service label (attached to the unit). Refer to the "1.5. Using R410A refrigerant air conditioners" for more information.

- Be careful when installing multiple units. Connecting to an incorrect indoor unit can lead to abnormally high pressure and have a serious effect on operation performance.

Model	Max pipe length	Max height difference	Additional refrigerant charging amount (kg/oz)										
			20 m 70 ft	25 m 80 ft	27 m 90 ft	30 m 100 ft	33.5 m 110 ft	36.6 m 120 ft	40 m 130 ft	43 m 140 ft	45.5 m 150 ft	48.8 m 160 ft	50 m 165 ft
A12, A18	30 m, 100 ft	30 m, 100 ft	0	0.06 kg 2 oz	0.11 kg 4 oz	0.17 kg 6 oz	—	—	—	—	—	—	—
A24, A30, A36	50 m, 165 ft	30 m, 100 ft	0	0.17 kg 6 oz	0.34 kg 12 oz	0.51 kg 18 oz	0.68 kg 24 oz	0.85 kg 30 oz	1.02 kg 36 oz	1.19 kg 42 oz	1.36 kg 48 oz	1.53 kg 54 oz	1.70 kg 60 oz
A42	50 m, 165 ft	30 m, 100 ft	0	0	0	0	0.17 kg 6 oz	0.34 kg 12 oz	0.51 kg 18 oz	0.68 kg 24 oz	0.85 kg 30 oz	1.02 kg 36 oz	1.19 kg 42 oz

## 4. Installing the refrigerant piping

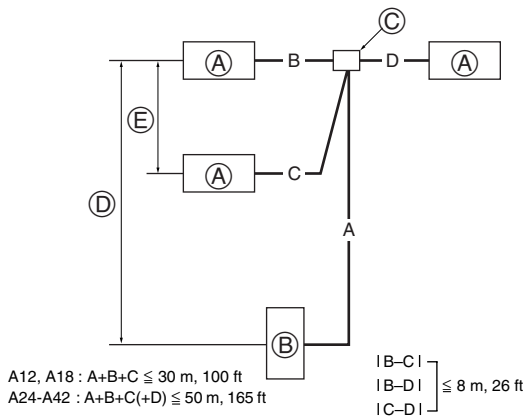

Fig. 4-7

### 4.7. For twin/triple combination

Refrigerant piping limitation of length, height difference are shown in the figure. (Fig. 4-7)

- Ⓐ Indoor unit
- Ⓑ Outdoor unit
- Ⓒ Multi distribution pipe (option)
- Ⓓ Height difference (Indoor unit-Outdoor unit) Max. 30 m, 100 ft
- Ⓔ Height difference (Indoor unit-Indoor unit) Max. 1 m, 3 ft

## 5. Drainage piping work

### Outdoor unit drainage pipe connection

When drain piping is necessary, use the drain socket or the drain pan (option).

	A12, A18	A24-A42
Drain socket	PAC-SG61DS-E	
Drain pan	PAC-SG63DP-E	PAC-SG64DP-E

## 6. Electrical work

### 6.1. Outdoor unit (Fig. 6-1, Fig. 6-2)

- ① Remove the service panel.
- ② Wire the cables referring to the Fig. 6-1 and the Fig. 6-2.

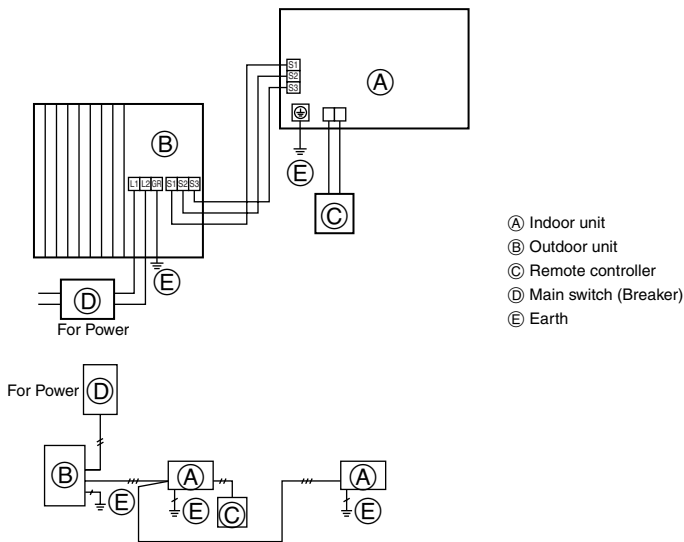

Fig. 6-1

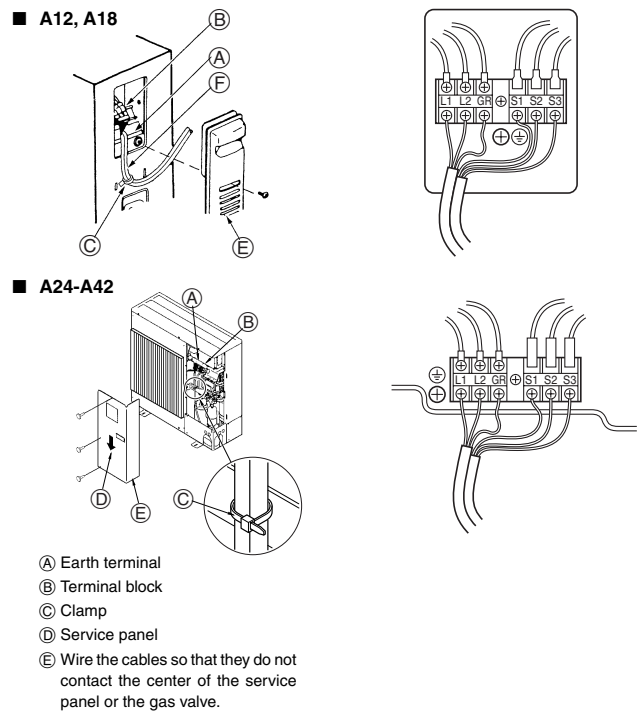
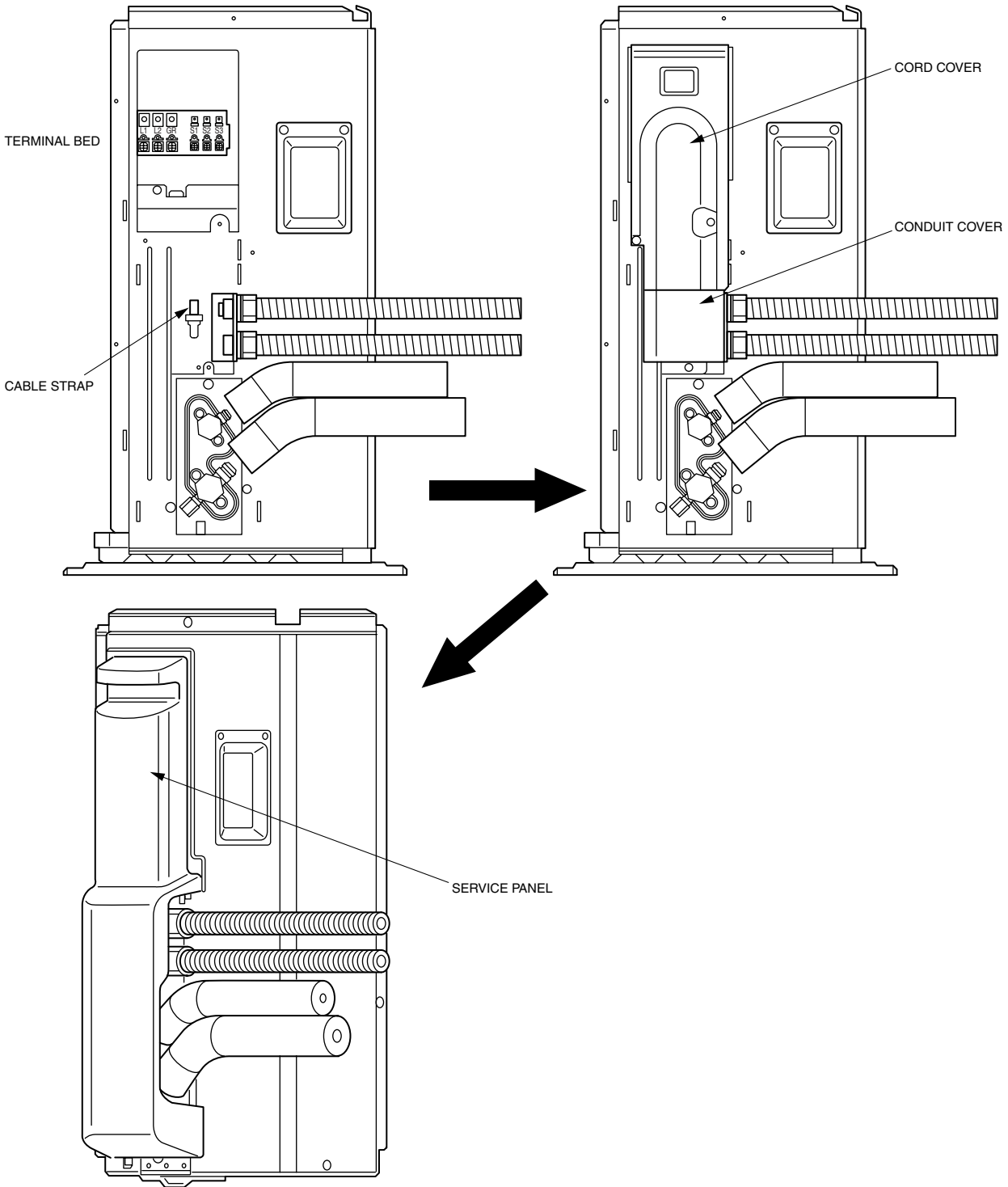

Fig. 6-2

■ A12, A18



■ A24-42

CONDUIT PLATE : accessory

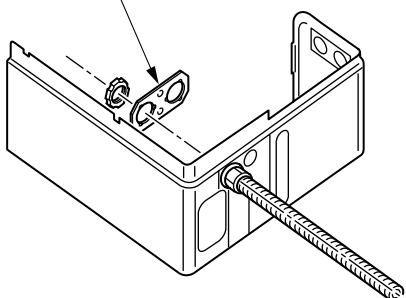



## 6. Electrical work

### 6.2. Field electrical wiring

Outdoor unit model		A12	A18	A24	A30	A36	A42
Outdoor unit power supply		Single, 208/230 V, 60 Hz	Single, 208/230 V, 60 Hz	Single, 208/230 V, 60 Hz	Single, 208/230 V, 60 Hz	Single, 208/230 V, 60 Hz	Single, 208/230 V, 60 Hz
Breaker size		15A	15A	25A	30A	30A	30A
Minimum circuit ampacity		13A	13A	18A	25A	25A	26A
Maximum rating of overcurrent protective device		15A	20A	30A	40A	40A	40A
Wiring Wire No. x size	Outdoor unit power supply	2 x Min. AWG 14	2 x Min. AWG 14	2 x Min. AWG 12	2 x Min. AWG 10	2 x Min. AWG 10	2 x Min. AWG 10
	Outdoor unit power supply earth	1 x Min. AWG 14	1 x Min. AWG 14	1 x Min. AWG 12	1 x Min. AWG 10	1 x Min. AWG 10	1 x Min. AWG 10
	Indoor unit-Outdoor unit	*1 3 x AWG 16 (polar)	3 x AWG 16 (polar)	3 x AWG 16 (polar)	3 x AWG 16 (polar)	3 x AWG 16 (polar)	3 x AWG 16 (polar)
	Indoor unit earth	*1 1 x Min. AWG 16	1 x Min. AWG 16	1 x Min. AWG 16	1 x Min. AWG 16	1 x Min. AWG 16	1 x Min. AWG 16
Circuit rating	Remote controller-Indoor unit	*2 2 x AWG 22 (Non-polar)	2 x AWG 22 (Non-polar)	2 x AWG 22 (Non-polar)	2 x AWG 22 (Non-polar)	2 x AWG 22 (Non-polar)	2 x AWG 22 (Non-polar)
	Outdoor unit L1-L2	*3 AC 208/230 V	AC 208/230 V	AC 208/230 V	AC 208/230 V	AC 208/230 V	AC 208/230 V
	Indoor unit-Outdoor unit S1-S2	*3 AC 208/230 V	AC 208/230 V	AC 208/230 V	AC 208/230 V	AC 208/230 V	AC 208/230 V
	Indoor unit-Outdoor unit S2-S3	*3 DC 24 V	DC 24 V	DC 24 V	DC 24 V	DC 24 V	DC 24 V
	Remote controller-Indoor unit	*3 DC 12 V	DC 12 V	DC 12 V	DC 12 V	DC 12 V	DC 12 V

\*1. Max. 50 m, 165 ft

\*2. The 10 m, 30 ft wire is attached in the remote controller accessory. Max 1500 ft

\*3. The figures are NOT always against the ground.

S3 terminal has DC 24 V against S2 terminal. However between S3 and S1, these terminals are NOT electrically insulated by the transformer or other device.

- Notes:**
1. Wiring size must comply with the applicable local and national code.
  2. Use copper supply wires.
  3. Use wires rated 300V or more for the power supply cables and the indoor/outdoor unit connecting cables.
  4. Install an earth longer than other cables.

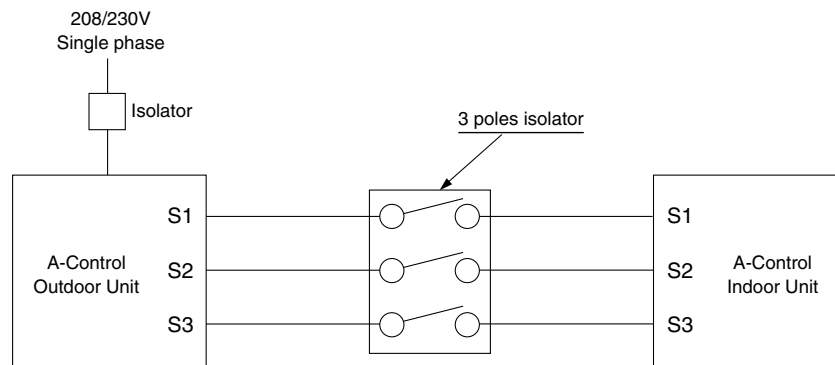

#### ⚠ Warning:

In case of A-control wiring, there is high voltage potential on the S3 terminal caused by electrical circuit design that has no electrical insulation between power line and communication signal line. Therefore, please turn off the main power supply when servicing. And do not touch the S1, S2, S3 terminals when the power is energized. If isolator should be used between indoor unit and outdoor unit, please use 3-poles type.

## 7. Test run

### 7.1. Before test run

- ▶ After completing installation and the wiring and piping of the indoor and outdoor units, check for refrigerant leakage, looseness in the power supply or control wiring, wrong polarity, and no disconnection of one phase in the supply.
- ▶ Use a 500-volt megohmmeter to check that the resistance between the power supply terminals and ground is at least 1.0MΩ.
- ▶ Do not carry out this test on the control wiring (low voltage circuit) terminals.

#### ⚠ Warning:

Do not use the air conditioner if the insulation resistance is less than 1.0MΩ.

#### Insulation resistance

After installation or after the power source to the unit has been cut for an extended period, the insulation resistance will drop below 1 MΩ due to refrigerant accumulating in the compressor. This is not a malfunction. Perform the following procedures.

1. Remove the wires from the compressor and measure the insulation resistance of the compressor.
2. If the insulation resistance is below 1 MΩ, the compressor is faulty or the resistance dropped due the accumulation of refrigerant in the compressor.
3. After connecting the wires to the compressor, the compressor will start to warm up after power is supplied. After supplying power for the times indicated below, measure the insulation resistance again.
  - The insulation resistance drops due to accumulation of refrigerant in the compressor. The resistance will rise above 1 MΩ after the compressor is warmed up for two to three hours.

(The time necessary to warm up the compressor varies according to atmospheric conditions and refrigerant accumulation.)

- To operate the compressor with refrigerant accumulated in the compressor, the compressor must be warmed up at least 12 hours to prevent breakdown.
4. If the insulation resistance rises above 1 MΩ, the compressor is not faulty.

#### ⚠ Caution:

- The compressor will not operate unless the power supply phase connection is correct.
- Turn on the power at least 12 hours before starting operation.
- Starting operation immediately after turning on the main power switch can result in severe damage to internal parts. Keep the power switch turned on during the operational season.

#### ▶ The followings must be checked as well.

- The outdoor unit is not faulty. LED1 and LED2 on the control board of the outdoor unit flash when the outdoor unit is faulty.
- Both the gas and liquid stop valves are completely open.
- A protective sheet covers the surface of the DIP switch panel on the control board of the outdoor unit. Remove the protective sheet to operate the DIP switches easily.
- Make sure that the all of the SW5 DIP switches for function changes on the control board of the outdoor unit are set to OFF. If all of the SW5 switches are not set to OFF, record the settings and then set all of the switches to OFF. Begin recovering the refrigerant. After moving the unit to a new location and completing the test run, set the SW5 switches to the previously recorded settings.

## 7. Test run

### 7.2. Test run

#### 7.2.1. Using SW4 in outdoor unit

##### 1) PUH Type, PUZ Type

SW4-1	ON	Cooling operation
SW4-2	OFF	
SW4-1	ON	Heating operation
SW4-2	ON	

##### 2) PUY Type

SW4-1	ON	Cooling operation
SW4-2	ON or OFF	

\* After performing the test run, set SW4-1 to OFF.

- After power is supplied, a small clicking noise may be heard from the inside of the outdoor unit. The electronic expansion valve is opening and closing. The unit is not faulty.
- A few seconds after the compressor starts, a clanging noise may be heard from the inside of the outdoor unit. The noise is coming from the check valve due to the small difference in pressure in the pipes. The unit is not faulty.

**The test run operation mode cannot be changed by DIP switch SW4-2 during the test run. (To change the test run operation mode during the test run, stop the test run by DIP switch SW4-1. After changing the test run operation mode, resume the test run by switch SW4-1.)**

#### 7.2.2. Using remote controller

Refer to the indoor unit installation manual.

## 8. Special Functions

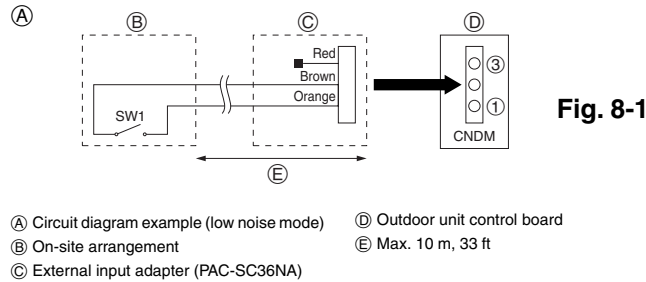

### 8.1. Low noise mode (on-site modification) (Fig. 8-1)

By performing the following modification, operation noise of the outdoor unit can be reduced by about 3-4 dB.

The low noise mode will be activated when a commercially available timer or the contact input of an ON/OFF switch is added to the CNDM connector (option) on the control board of the outdoor unit.

- The ability varies according to the outdoor temperature and conditions, etc.

- ① Complete the circuit as shown when using the external input adapter (PAC-SC36NA). (Option)
- ② SW1 ON: Low noise mode  
SW1 OFF: Normal operation

### 8.2. Refrigerant collecting (pump down)

Perform the following procedures to collect the refrigerant when moving the indoor unit or the outdoor unit.

- ① Before collecting the refrigerant, first make sure that all of the SW5 DIP switches for function changes on the control board of the outdoor unit are set to OFF. If all of the SW5 switches are not set to OFF, record the settings and then set all of the switches to OFF. Start collecting the refrigerant. After moving the unit to a new location and completing the test run, set the SW5 switches to the previously recorded settings.
- ② Supply power (circuit breaker).
  - \* When power is supplied, make sure that "CENTRALLY CONTROLLED" is not displayed on the remote controller. If "CENTRALLY CONTROLLED" is displayed, the refrigerant collecting (pump down) cannot be completed normally.
- ③ After the gas stop valve is closed, set the SWP switch on the control board of the outdoor unit to ON. The compressor (outdoor unit) and ventilators (indoor and outdoor units) start operating and refrigerant collecting operation begins. LED1 and LED2 on the control board of the outdoor unit are lit.

- \* Only set the SWP switch (push-button type) to ON if the unit is stopped. However, even if the unit is stopped and the SWP switch is set to ON less than three minutes after the compressor stops, the refrigerant collecting operation cannot be performed. Wait until compressor has been stopped for three minutes and then set the SWP switch to ON again.

- ④ Because the unit automatically stops in about two to three minutes after the refrigerant collecting operation (LED1 and LED2 are lit), be sure to quickly close the gas stop valve. When LED1 and LED2 are lit and the outdoor unit is stopped, open the liquid stop valve completely, and then repeat step ③ after three minutes have passed.
  - \* If the refrigerant collecting operation has been completed normally (LED1 and LED2 are lit), the unit will remain stopped until the power supply is turned off.
- ⑤ Turn off the power supply (circuit breaker).

## 9. System control (Fig. 9-1)

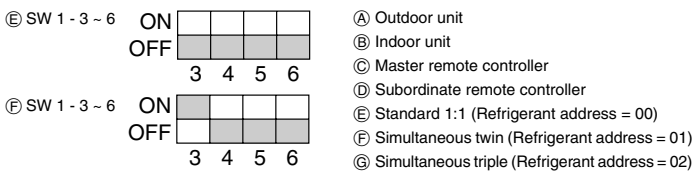

\* Set the refrigerant address using the DIP switch of the outdoor unit.

#### ① Wiring from the Remote Control

This wire is connected to TB5 (terminal board for remote controller) of the indoor unit (non-polar).

#### ② When a Different Refrigerant System Grouping is Used.

Up to 16 refrigerant systems can be controlled as one group using the slim MA remote controller.

#### Note:

**In single refrigerant system (twin/triple), there is no need of wiring ②.**

SW1 Function table

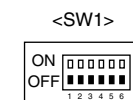

SW1 function settings	Function	Operation according to switch setting	
		ON	OFF
1	Compulsory defrosting	Start	Normal
2	Error history clear	Clear	Normal
3	Refrigerant system address setting	Settings for outdoor unit addresses 0 to 15	
4			
5			
6			

**Fig. 9-1**

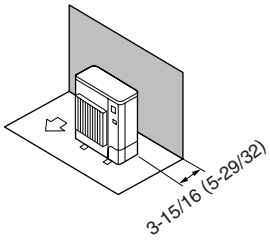

Fig. 2-6

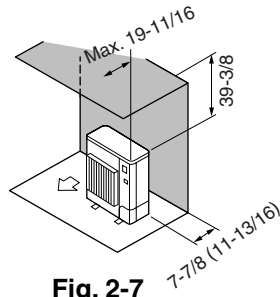

Fig. 2-7

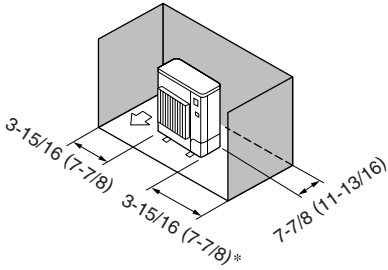

Fig. 2-8

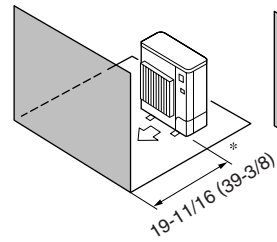

Fig. 2-9

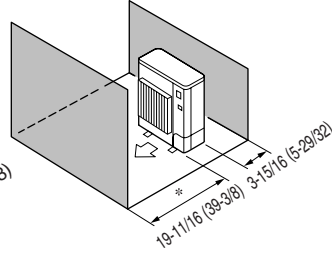

Fig. 2-10

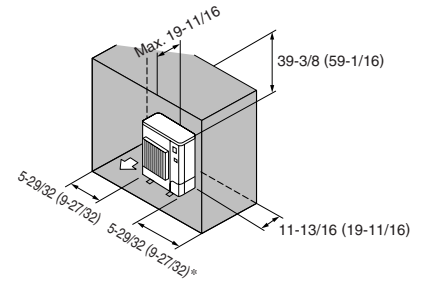

Fig. 2-11

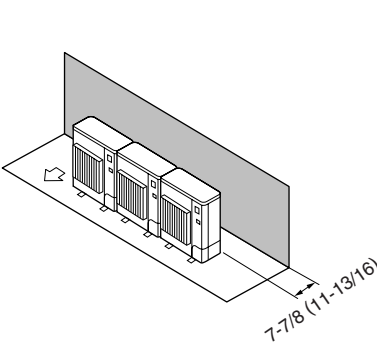

Fig. 2-12

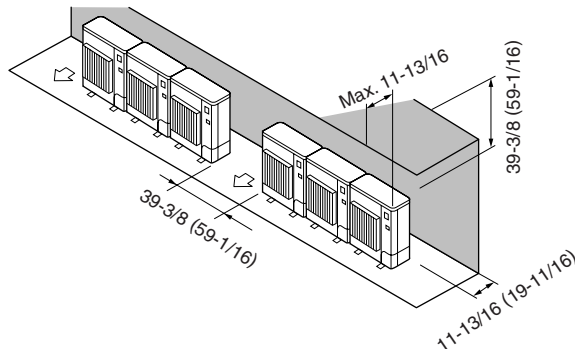

Fig. 2-13

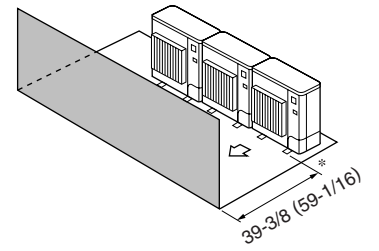

Fig. 2-14

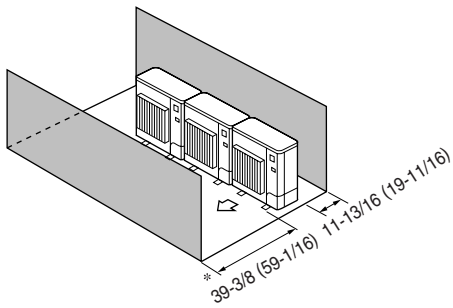

Fig. 2-15

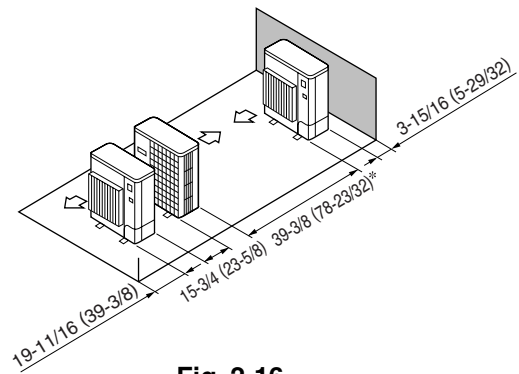

Fig. 2-16

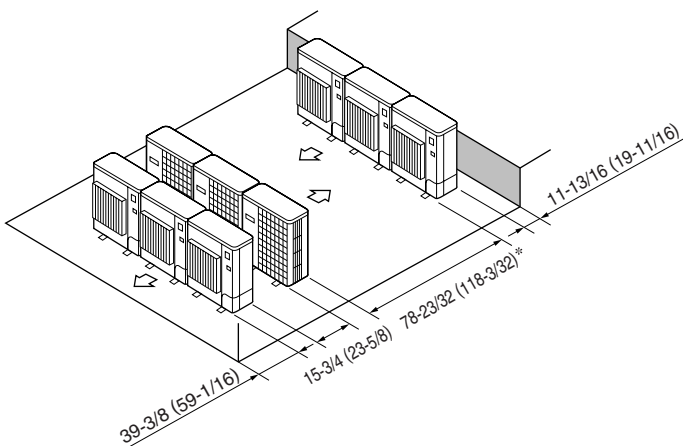

Fig. 2-17

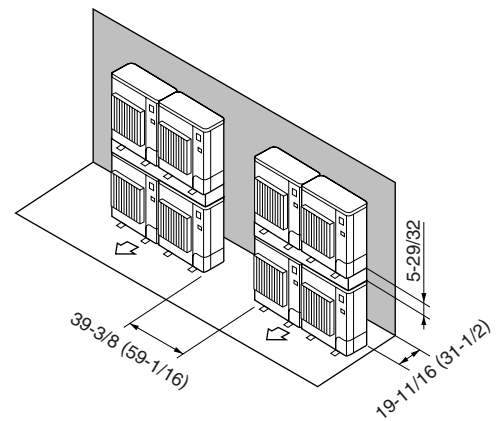

Fig. 2-18



## HVAC Advanced Products Division

---

3400 Lawrenceville Suwanee Road • Suwanee, Georgia 30024  
Toll Free: 800-433-4822 • Toll Free Fax: 800-889-9904  
[www.mrslim.com](http://www.mrslim.com)

**Specifications are subject to change without notice.**