

HEAT PUMPS

RUUD
ACHIEVER
 Series

UPMD- SERIES

Seven Models

12 SEER with efficiencies ranging up to 14 SEER in certain matched systems.
 Nominal Sizes 1 1/2 to 5 Tons
 [5.28 kW] to [17.58 kW]



The *Ruud Achiever Series*[®] UPMD- Heat Pump Outdoor units can provide year-round heating and cooling comfort for residential, multi-family and light commercial applications. They are designed to operate with Ruud indoor units with cooling and heating capacities certified under the ARI Certification program.

The Ruud UBHC- and UBHK- Air Handlers equipped with auxiliary heating elements for supplementary heat were designed especially for use with the UPMD- Heat Pump. Together they provide systems capable of delivering a maximum HSPF (Heating Seasonal Performance Factor) of 8.80 in the heating mode or a maximum standard S.E.E.R. (Seasonal Energy Efficiency Ratio) of 14.0 in the cooling mode.

The following additional features, plus its energy-saving characteristics, make the UPMD- Heat Pump outdoor unit an excellent choice for new construction or upgrading your present system.

- Attractive, louvered wrap around jacket protects coil from weather extremes and yard hazards. Top grille is steel reinforced for extra strength. Cabinet is powder painted for all weather protection.
- Four sided outdoor coil design allows compressor operation with access panel removed.
- Air is discharged upward away from bushes and shrubs. The discharge pattern of the top grille provides minimum air restriction.
- Exclusive Combination Grille/Motor Mount* secures the fan motor to the underside of the discharge grille. The grille protects the motor windings and bearings from rain and snow.
- All controls are accessible by removing one service panel. Removable top grille provides access to the outdoor fan motor and outdoor coil.
- Compressor compartment offers additional protection from the elements and reduces operating noise.
- Single speed, 6-pole fan motor is designed for low speed, quiet, energy-saving operation.
- Non-cycling reversing valve and demand defrost.
- All models meet or exceed a 1000-hour salt spray test per ASTM B117 Standard Practice for Operating Salt Spray Testing Apparatus.

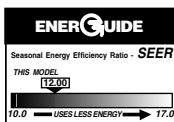

"CERTIFIED UNDER THE
 A.R.I. CERTIFICATION
 PROGRAM—A.R.I. STANDARD 240-81"

*Patented

Engineering Features

UPMD- Series Heat Pump Outdoor Unit

- Scroll Compressor**—is hermetically sealed and incorporates internal high temperature motor overload protection, and durable insulation on the motor windings. It is externally mounted on rubber grommets to reduce vibration and noise.
- Copper Tube/Aluminum Fin Coils**—Both indoor and outdoor coils.
- Strong, Attractive Cabinet**—Constructed of powder painted steel. Louvered design protects the coil from damage.
- Internal Check Valve**—Provides for quiet refrigerant metering.
- Refrigerant Metering**—Expansion valves accurately meter refrigerant into indoor and outdoor coils.
- Manual Reset High Pressure Control**—Deactivates system if abnormally high pressure occurs.
- Drawn, painted base pan**—for extra corrosion resistance.
- Hard Start Components**—Offer additional starting torque to cover a wide range of voltage and pressure variations.
- PTC Self-Regulating Crankcase Heaters (only on 3 phase models)**—Conserve energy.
- Demand Defrost Control**—Provides complete defrost when defrost is required.
- Non-Cycling Reversing Valve**—Eliminates discharge noises on each heating cycle.
- Hot Gas Muffler**—Reduces noise in heating cycle and cooling cycle.
- Suction Line Accumulator**—Provides protection for the compressor.
- Bi-Directional Filter Drier**—Provided on all models.
- Service valves** are standard on all models.

Convenience Features

- **The scroll compressor models (single phase only), additionally have a 10 year compressor warranty as standard.**
- All refrigerant connections are on the exterior of the unit, located close to the ground for neat appearing installations.
- Coil design permits compressor operation with the access panel removed.
- Control box is fully accessible in the upper part of the cabinet, just under the access panel.
- Power and control wiring are kept separate.
- Every unit is factory charged and tested.



All controls and compressor are accessible for servicing by removal of the service panel.

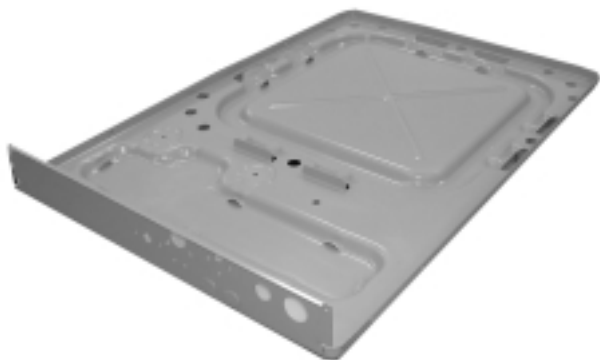

Drawn Painted Base Pan.

Accessories

- **Low Ambient Control**—Allows low temperature operation in the cooling cycle down to 0°F [-17.8°C] outdoor temperature. It is recommended that this control be installed in units to be operated for cooling at outdoor ambient temperatures under 65°F [18°C]. (Model No. RXPZ-C01)
- **Outdoor Thermostats**—
 - RXPT-A01—One outdoor thermostat in box.
 - RXPT-A02—One outdoor thermostat for mounting in box for use with RXPT-A01 or A03.
 - RXPT-A03—One outdoor thermostat with emergency Heat Relay wired and mounted in box.
 - RXPT-A04—Two outdoor thermostats with emergency Heat Relay wired and mounted in box.
- **Heat Pump Monitor**—Indicates inefficient operation or malfunction of heat pump. (Model No. RXPM-B01)
- **Thermostats and Subbases**—Available through PROSTOCK®.
- **Compressor Time Delay Control**—Compressor will remain off for five minutes after power or thermostat interruption, allowing system pressures to equalize. Starting during high pressure conditions can result in shortened compressor life. (Model No. RXMD-B01)
- **Blower Time Delay Control**—RXMD-C02.
- **Fossil Fuel Kits**—RXPF-01
RXPF-02

Model Number Identification

<u>U</u>	<u>P</u>	<u>M</u>	<u>D</u>	—	<u>024</u>	<u>J</u>	<u>A</u>	<u>Z</u>
RUUD	REMOTE HEAT PUMP	HIGH EFFICIENCY (STANDARD)	DESIGN SERIES D = FOURTH DESIGN		COOLING CAPACITY	ELECTRICAL DESIGNATION	VARIATIONS A = STANDARD	COOLING CONNECTION FITTING Z = SWEAT W/SCROLL
					018 = 18,000 BTU/HR [5.28 kW] 024 = 24,000 BTU/HR [7.03 kW] 030 = 30,000 BTU/HR [8.79 kW] 036 = 36,000 BTU/HR [10.55 kW] 042 = 42,000 BTU/HR [12.31 kW] 048 = 48,000 BTU/HR [14.07 kW] 060 = 60,000 BTU/HR [17.58 kW]	J = 208/230V-1-60 C = 208-230V-3-60		

[] Designates Metric Conversions

Ruud Heat Pump System

For all season home comfort, performance and energy conservation, choose a Ruud UPMD- Series Heat Pump and UBHK- or UBHC- Series Air Handler.

More than a reverse cycle air conditioner, it's a specially designed combination Winter/Summer comfort system using an indoor coil for heating and cooling.

To choose an UBHK- or UBHC- Air Handler designed for use with the UPMD- Heat Pump, refer to the Performance Data Tables and/or the air handler specification sheet.

COPELAND® SCROLL® COMPRESSOR

The Copeland scroll compressor is the key to efficiency for this Ruud model. It's the latest in high-efficiency compressor technology. The advanced scroll compressor offers low noise and vibration characteristics and features tolerance to liquid refrigerant and system contamination. The Copeland Scroll also has low start torque, reducing start problems in the field. And its unique design enables the UPMD- heat pump to perform efficiently, quietly and reliably.



Performance Data ARI Standard Conditions

Note: Only these combinations of indoor/outdoor units are approved and any other combinations should not be used.

Model Numbers		ARI Cooling Performance							ARI Heating Performance (70°F [21°C] Indoor)							
		80°F [26.5°C] DB/67°F [19.5°C] WB Indoor Air 95°F [35°C] DB Outdoor Air							Outdoor Air 47°F [8.5°C] DB/ 43°F [6°C] WB DOE High Temp.			Outdoor Air 17°F [-8.5°C] DB/ 15°F [-9.5°C] WB DOE Low Temp.			DOE Region IV HSPF	DOE Region V HSPF
Outdoor Unit UPMD-	Indoor Coil and/or Air Handler	Total Capacity BTU/H [kW]	Net Sens. BTU/H [kW]	Net Latent BTU/H [kW]	EER	SEER	Sound Rating	Indoor CFM [L/s]	BTU/H [kW]	Total Watts	COP	BTU/H [kW]	Total Watts	COP		
018JA	RCBA-2457+RXCT-CHA	18,000 [5.3]	12,600 [3.7]	5,400 [1.6]	10.50	12.00	7.4	600 [283]	18,200 [5.3]	1,666	3.20	11,200 [3.3]	1,427	2.30	8.00	7.00
	RCHA-24A1 ①	18,000 [5.3]	12,600 [3.7]	5,400 [1.6]	10.50	12.00	7.4	600 [283]	18,200 [5.3]	1,666	3.20	11,200 [3.3]	1,427	2.30	8.00	7.00
	UBHC-14+RCBA-2457+RXCT-CHA	18,000 [5.3]	12,900 [3.8]	5,100 [1.5]	10.50	12.20	7.4	600 [283]	18,400 [5.4]	1,685	3.20	11,700 [3.4]	1,517	2.26	8.25	7.15
	UBHC-14+RCHA-24A1	18,000 [5.3]	12,900 [3.8]	5,100 [1.5]	10.50	12.20	7.4	600 [283]	18,400 [5.4]	1,685	3.20	11,700 [3.4]	1,517	2.26	8.25	7.15
	UBHC-15+RCBA-2457+RXCT-CHA	18,000 [5.3]	12,900 [3.8]	5,100 [1.5]	10.50	12.20	7.4	600 [283]	18,400 [5.4]	1,685	3.20	11,700 [3.4]	1,517	2.26	8.25	7.15
	UBHC-15+RCHA-24A1	18,000 [5.3]	12,900 [3.8]	5,100 [1.5]	10.50	12.20	7.4	600 [283]	18,400 [5.4]	1,685	3.20	11,700 [3.4]	1,517	2.26	8.25	7.15
	UBHK-17+RCBA-2457+RXCT-CHA	18,500 [5.4]	13,400 [3.9]	5,100 [1.5]	11.80	13.75	7.4	600 [283]	17,900 [5.2]	1,533	3.42	11,200 [3.3]	1,379	2.38	8.60	7.40
	UBHK-17+RCHA-24A1	18,500 [5.4]	13,400 [3.9]	5,100 [1.5]	11.80	13.75	7.4	600 [283]	17,900 [5.2]	1,533	3.42	11,200 [3.3]	1,379	2.38	8.60	7.40
	UBHK-17+RCHJ-24A1	18,500 [5.4]	13,400 [3.9]	5,100 [1.5]	11.80	13.75	7.4	600 [283]	17,900 [5.2]	1,533	3.42	11,200 [3.3]	1,379	2.38	8.60	7.40
	UGLL-05?BMK?+RCHA-24A1	18,500 [5.4]	13,400 [3.9]	5,100 [1.5]	11.75	13.75	7.4	600 [283]	17,900 [5.2]	1,533	3.42	11,200 [3.3]	1,379	2.38	8.60	7.40
	UGPL-05?BMK?+RCHA-24A1	18,500 [5.4]	13,400 [3.9]	5,100 [1.5]	11.75	13.75	7.4	600 [283]	17,900 [5.2]	1,533	3.42	11,200 [3.3]	1,379	2.38	8.60	7.40
024JA	RCBA-2457+RXCT-CHB	22,600 [6.6]	16,200 [4.7]	6,400 [1.9]	10.50	12.00	7.4	800 [378]	23,800 [7.0]	2,179	3.20	14,800 [4.3]	1,886	2.30	8.00	7.00
	RCHA-24A2 ①	22,600 [6.6]	16,200 [4.7]	6,400 [1.9]	10.50	12.00	7.4	800 [378]	23,800 [7.0]	2,179	3.20	14,800 [4.3]	1,886	2.30	8.00	7.00
	UBHC-14+RCBA-2457+RXCT-CHB	22,400 [6.6]	16,400 [4.8]	6,000 [1.8]	10.60	12.00	7.4	800 [378]	22,400 [6.6]	2,026	3.24	15,000 [4.4]	1,980	2.22	7.90	7.20
	UBHC-14+RCHA-24A2	22,400 [6.6]	16,400 [4.8]	6,000 [1.8]	10.60	12.00	7.4	800 [378]	22,400 [6.6]	2,026	3.24	15,000 [4.4]	1,980	2.22	7.90	7.20
	UBHC-15+RCBA-2457+RXCT-CHB	22,400 [6.6]	16,400 [4.8]	6,000 [1.8]	10.60	12.00	7.4	800 [378]	22,400 [6.6]	2,026	3.24	15,000 [4.4]	1,980	2.22	7.90	7.20
	UBHC-15+RCHA-24A2	22,400 [6.6]	16,400 [4.8]	6,000 [1.8]	10.60	12.00	7.4	800 [378]	22,400 [6.6]	2,026	3.24	15,000 [4.4]	1,980	2.22	7.90	7.20
	UBHK-17+RCBA-2457+RXCT-CHB	23,000 [6.7]	17,000 [5.0]	6,000 [1.8]	11.85	13.60	7.4	800 [378]	21,800 [6.4]	1,857	3.44	14,300 [4.2]	1,791	2.34	8.25	7.40
	UBHK-17+RCHA-24A2	23,000 [6.7]	17,000 [5.0]	6,000 [1.8]	11.85	13.60	7.4	800 [378]	21,800 [6.4]	1,857	3.44	14,300 [4.2]	1,791	2.34	8.25	7.40
	UBHK-17+RCHJ-24A2	23,000 [6.7]	17,000 [5.0]	6,000 [1.8]	11.85	13.60	7.4	800 [378]	21,800 [6.4]	1,857	3.44	14,300 [4.2]	1,791	2.34	8.25	7.40
	UGLL-05?BMK?+RCHA-24A2	23,200 [6.8]	17,100 [5.0]	6,100 [1.8]	12.05	13.80	7.4	800 [378]	21,800 [6.4]	1,835	3.48	14,300 [4.2]	1,775	2.36	8.30	7.45
UGPL-05?BMK?+RCHA-24A2	23,200 [6.8]	17,100 [5.0]	6,100 [1.8]	12.00	13.75	7.4	800 [378]	21,800 [6.4]	1,846	3.46	14,300 [4.2]	1,775	2.36	8.30	7.45	
030JA	RCBA-3765+RXCT-CHC	27,200 [8.0]	19,500 [5.7]	7,700 [2.3]	10.50	12.00	7.4	1,000 [472]	28,400 [8.3]	2,485	3.34	17,600 [5.2]	2,345	2.20	8.00	7.00
	RCHA-36A1 ①	27,200 [8.0]	19,500 [5.7]	7,700 [2.3]	10.50	12.00	7.4	1,000 [472]	28,400 [8.3]	2,485	3.34	17,600 [5.2]	2,345	2.20	8.00	7.00
	UBHC-17+RCBA-3765+RXCT-CHC	27,000 [7.9]	19,600 [5.7]	7,400 [2.2]	10.50	12.10	7.4	1,000 [472]	28,600 [8.4]	2,540	3.30	17,400 [5.1]	2,360	2.16	7.90	6.85
	UBHC-17+RCHA-36A1	27,000 [7.9]	19,600 [5.7]	7,400 [2.2]	10.50	12.10	7.4	1,000 [472]	28,600 [8.4]	2,540	3.30	17,400 [5.1]	2,360	2.16	7.90	6.85
	UBHC-18+RCBA-3765+RXCT-CHC	27,000 [7.9]	19,600 [5.7]	7,400 [2.2]	10.50	12.00	7.4	1,000 [472]	28,600 [8.4]	2,540	3.30	17,400 [5.1]	2,360	2.16	7.90	6.85
	UBHC-18+RCHA-36A1	27,000 [7.9]	19,600 [5.7]	7,400 [2.2]	10.50	12.10	7.4	1,000 [472]	28,600 [8.4]	2,540	3.30	17,400 [5.1]	2,360	2.16	7.90	6.85
	UBHK-21+RCBA-3765+RXCT-CHC	27,800 [8.1]	20,400 [6.0]	7,400 [2.2]	11.80	13.75	7.4	1,000 [472]	27,800 [8.1]	2,314	3.52	16,600 [4.9]	2,133	2.28	8.25	7.10
	UBHK-21+RCHA-36A1	27,800 [8.1]	20,400 [6.0]	7,400 [2.2]	11.80	13.75	7.4	1,000 [472]	27,800 [8.1]	2,314	3.52	16,600 [4.9]	2,133	2.28	8.25	7.10

① Highest sales volume tested combination required by D.O.E. test procedures.

[] Designates Metric Conversions

Performance Data ARI Standard Conditions (cont.)

Note: Only these combinations of indoor/outdoor units are approved and any other combinations should not be used.

Model Numbers		ARI Cooling Performance							ARI Heating Performance (70°F [21°C] Indoor)							
		80°F [26.5°C] DB/67°F [19.5°C] WB Indoor Air 95°F [35°C] DB Outdoor Air							Outdoor Air 47°F [8.5°C] DB/ 43°F [6°C] WB DOE High Temp.			Outdoor Air 17°F [-8.5°C] DB/ 15°F [-9.5°C] WB DOE Low Temp.			DOE Region IV HSPF	DOE Region V HSPF
Outdoor Unit UPMD-	Indoor Coil and/or Air Handler	Total Capacity BTU/H [kW]	Net Sens. BTU/H [kW]	Net Latent BTU/H [kW]	EER	SEER	Sound Rating	Indoor CFM [L/s]	BTU/H [kW]	Total Watts	COP	BTU/H [kW]	Total Watts	COP		
030JA	UBHK-21+RCHJ-36A1	27,800 [8.1]	20,400 [6.0]	7,400 [2.2]	11.80	13.75	7.4	1,000 [472]	27,800 [8.1]	2,314	3.52	16,600 [4.9]	2,133	2.28	8.25	7.10
	UGLL-05?BMK?+RCHA-36A1	27,600 [8.1]	20,200 [5.9]	7,400 [2.2]	11.70	13.65	7.4	1,000 [472]	27,800 [8.1]	2,327	3.50	16,700 [4.9]	2,165	2.26	8.20	7.05
	UGLL-07?BRK?+RCHA-36A1	27,800 [8.1]	20,400 [6.0]	7,400 [2.2]	11.80	13.70	7.4	1,000 [472]	27,800 [8.1]	2,314	3.52	16,700 [4.9]	2,146	2.28	8.20	7.10
	UGLL-07?BRQ?+RCHA-36A1	27,400 [8.0]	20,000 [5.9]	7,400 [2.2]	11.30	13.15	7.4	1,000 [472]	28,200 [8.3]	2,402	3.44	16,900 [5.0]	2,211	2.24	8.10	7.00
	UGPL-05?BMK?+RCHA-36A1	27,600 [8.1]	20,200 [5.9]	7,400 [2.2]	11.65	13.55	7.4	1,000 [472]	28,000 [8.2]	2,344	3.50	16,700 [4.9]	2,165	2.26	8.20	7.05
	UGPL-07?BRK?+RCHA-36A1	27,800 [8.1]	20,400 [6.0]	7,400 [2.2]	11.85	13.80	7.4	1,000 [472]	27,800 [8.1]	2,314	3.52	16,600 [4.9]	2,133	2.28	8.25	7.10
	UGPL-07?BRQ?+RCHA-36A1	27,600 [8.1]	20,200 [5.9]	7,400 [2.2]	11.55	13.45	7.4	1,000 [472]	28,000 [8.2]	2,358	3.48	16,800 [4.9]	2,178	2.26	8.20	7.05
036CA/JA	RCBA-3765+RXCT-CHK	33,400 [9.8]	23,400 [6.9]	10,000 [2.9]	10.50	12.00	7.6	1,200 [566]	35,800 [10.5]	3,180	3.30	23,200 [6.8]	2,893	2.34	8.00	7.00
	RCHA-36A2 ①	33,400 [9.8]	23,400 [6.9]	10,000 [2.9]	10.50	12.00	7.6	1,200 [566]	35,800 [10.5]	3,180	3.30	23,200 [6.8]	2,893	2.34	8.00	7.00
	UBHC-17+RCBA-3765+RXCT-CHK	33,000 [9.7]	23,900 [7.0]	9,100 [2.7]	10.35	12.00	7.6	1,200 [566]	37,400 [11.0]	3,362	3.26	24,000 [7.0]	3,031	2.32	8.20	7.15
	UBHC-17+RCHA-36A2	33,000 [9.7]	23,900 [7.0]	9,100 [2.7]	10.35	12.00	7.6	1,200 [566]	37,400 [11.0]	3,362	3.26	24,000 [7.0]	3,031	2.32	8.20	7.15
	UBHC-18+RCBA-3765+RXCT-CHK	33,000 [9.7]	23,900 [7.0]	9,100 [2.7]	10.35	12.00	7.6	1,200 [566]	37,400 [11.0]	3,362	3.26	24,000 [7.0]	3,031	2.32	8.20	7.15
	UBHC-18+RCHA-36A2	33,000 [9.7]	23,900 [7.0]	9,100 [2.7]	10.35	12.00	7.6	1,200 [566]	37,400 [11.0]	3,362	3.26	24,000 [7.0]	3,031	2.32	8.20	7.15
	UBHK-21+RCBA-3765+RXCT-CHK	33,800 [9.9]	24,700 [7.2]	9,100 [2.7]	11.40	13.35	7.6	1,200 [566]	36,600 [10.7]	3,316	3.42	23,200 [6.8]	2,786	2.44	8.60	7.45
	UBHK-21+RCHA-36A2	33,800 [9.9]	24,700 [7.2]	9,100 [2.7]	11.40	13.35	7.6	1,200 [566]	36,600 [10.7]	3,316	3.42	23,200 [6.8]	2,786	2.44	8.60	7.45
	UBHK-21+RCHJ-36A2	33,800 [9.9]	24,700 [7.2]	9,100 [2.7]	11.40	13.35	7.6	1,200 [566]	36,600 [10.7]	3,316	3.42	23,200 [6.8]	2,786	2.44	8.60	7.45
	UGLL-05?BMK?+RCHA-36A2	33,800 [9.9]	24,700 [7.2]	9,100 [2.7]	11.30	13.25	7.6	1,200 [566]	36,800 [10.8]	3,135	3.42	23,200 [6.8]	2,809	2.42	8.60	7.45
	UGLL-07?BRK?+RCHA-36A2	33,800 [9.9]	24,700 [7.2]	9,100 [2.7]	11.40	13.35	7.6	1,200 [566]	36,600 [10.7]	3,136	3.42	23,200 [6.8]	2,786	2.44	8.60	7.45
	UGLL-07?BRQ?+RCHA-36A2	33,200 [9.7]	24,100 [7.1]	9,100 [2.7]	10.65	12.40	7.6	1,200 [566]	37,200 [10.9]	3,303	3.30	23,800 [6.8]	2,955	2.36	8.35	7.30
	UGLL-10?BRM?+RCHA-36A2	33,800 [9.9]	24,700 [7.2]	9,100 [2.7]	11.35	13.30	7.6	1,200 [566]	36,600 [10.7]	3,136	3.42	23,200 [6.8]	2,786	2.44	8.60	7.45
	UGPL-05?BMK?+RCHA-36A2	33,600 [9.8]	24,500 [7.2]	9,100 [2.7]	11.10	13.00	7.6	1,200 [566]	36,800 [10.8]	3,190	3.38	23,400 [6.9]	2,857	2.40	8.50	7.40
	UGPL-07?BRK?+RCHA-36A2	33,800 [9.9]	24,700 [7.2]	9,100 [2.7]	11.35	13.35	7.6	1,200 [566]	36,600 [10.7]	3,136	3.42	23,200 [6.8]	2,786	2.44	8.60	7.45
	UGPL-07?BRQ?+RCHA-36A2	33,600 [9.8]	24,500 [7.2]	9,100 [2.7]	11.15	13.05	7.6	1,200 [566]	36,800 [10.8]	3,190	3.38	23,400 [6.9]	2,833	2.42	8.55	7.40
UGPL-10?BRM?+RCHA-36A2	33,600 [9.8]	24,500 [7.2]	9,100 [2.7]	11.15	13.05	7.6	1,200 [566]	36,800 [10.8]	3,190	3.38	23,400 [6.9]	2,857	2.40	8.50	7.40	
042CA/JA	RCBA-6089+RXCT-CHE	41,000 [12.0]	29,000 [8.5]	12,000 [3.5]	10.35	12.00	7.8	1,400 [661]	43,000 [12.6]	3,866	3.26	27,400 [8.0]	3,461	2.32	8.05	7.00
	RCHJ-48A1 ①	41,000 [12.0]	29,000 [8.5]	12,000 [3.5]	10.35	12.00	7.8	1,400 [661]	43,000 [12.6]	3,866	3.26	27,400 [8.0]	3,461	2.32	8.05	7.00
	UBHK-24+RCBA-6089+RXCT-CHE	41,000 [12.0]	29,300 [8.6]	11,700 [3.43]	11.45	13.20	7.8	1,400 [661]	42,000 [12.3]	3,457	3.56	27,000 [7.9]	3,165	2.50	8.65	7.50
	UBHK-24+RCHJ-48A1	41,000 [12.0]	29,300 [8.6]	11,700 [3.43]	11.45	13.20	7.8	1,400 [661]	42,000 [12.3]	3,457	3.56	27,000 [7.9]	3,165	2.50	8.65	7.50
	UGLL-07?BRQ?+RCHJ-48A1	40,500 [11.9]	28,700 [8.4]	11,800 [3.5]	10.65	12.20	7.8	1,400 [661]	43,000 [12.6]	3,684	3.42	27,800 [8.1]	3,394	2.40	8.35	7.35
	UGLL-10?BRM?+RCHJ-48A1	41,000 [12.0]	29,200 [8.6]	11,800 [3.5]	11.20	13.00	7.8	1,400 [661]	42,500 [12.5]	3,538	3.52	27,200 [7.8]	3,240	2.46	8.55	7.45

① Highest sales volume tested combination required by D.O.E. test procedures.

[] Designates Metric Conversions

Performance Data ARI Standard Conditions (cont.)

Note: Only these combinations of indoor/outdoor units are approved and any other combinations should not be used.

Model Numbers		ARI Cooling Performance							ARI Heating Performance (70°F [21°C] Indoor)							
		80°F [26.5°C] DB/67°F [19.5°C] WB Indoor Air 95°F [35°C] DB Outdoor Air							Outdoor Air 47°F [8.5°C] DB/ 43°F [6°C] WB DOE High Temp.			Outdoor Air 17°F [-8.5°C] DB/ 15°F [-9.5°C] WB DOE Low Temp.			DOE Region IV HSPF	DOE Region V HSPF
		Total Capacity BTU/H [kW]	Net Sens. BTU/H [kW]	Net Latent BTU/H [kW]	EER	SEER	Sound Rating	Indoor CFM [L/s]	BTU/H [kW]	Total Watts	COP	BTU/H [kW]	Total Watts	COP		
042CA/JA	UGLL-12?ARM?+RCHJ-48A1	41,000 [12.0]	29,200 [8.6]	11,800 [3.5]	11.25	13.00	7.8	1,400 [661]	42,500 [12.5]	3,538	3.52	27,200 [8.0]	3,240	2.46	8.55	7.45
	UGPL-07?BRQ?+RCHJ-48A1	40,500 [11.9]	28,800 [8.4]	11,700 [3.4]	10.90	12.50	7.8	1,400 [661]	42,500 [12.5]	3,600	3.46	27,400 [8.0]	3,291	2.44	8.45	7.40
	UGPL-10?BRM?+RCHJ-48A1	40,500 [11.9]	28,800 [8.4]	11,700 [3.4]	11.05	12.65	7.8	1,400 [661]	42,500 [12.5]	3,579	3.48	27,400 [8.0]	3,291	2.44	8.50	7.40
	UGPL-12?ARM?+RCHJ-48A1	41,000 [12.0]	29,300 [8.6]	11,700 [3.4]	11.30	13.00	7.8	1,400 [661]	42,500 [12.5]	3,518	3.54	27,200 [7.8]	3,214	2.48	8.60	7.45
048CA/JA	RCBA-6089+RXCT-CHH	46,500 [13.6]	33,200 [9.7]	13,300 [3.9]	10.65	12.00	7.8	1,600 [755]	48,500 [14.2]	4,208	3.38	31,000 [9.1]	3,541	2.58	8.35	7.10
	RCHJ-48A2 ①	46,500 [13.6]	33,200 [9.7]	13,300 [3.9]	10.65	12.00	7.8	1,600 [755]	48,500 [14.2]	4,208	3.38	31,000 [9.1]	3,541	2.58	8.35	7.10
	UBHK-24+RCBA-6089+RXCT-CHH	47,000 [13.8]	34,300 [10.0]	12,700 [3.7]	11.50	13.20	7.8	1,600 [755]	47,500 [13.9]	3,845	3.62	30,600 [9.0]	3,423	2.62	8.80	8.10
	UBHK-24+RCHJ-48A2	47,000 [13.8]	34,300 [10.0]	12,700 [3.7]	11.50	13.20	7.8	1,600 [755]	47,500 [13.9]	3,845	3.62	30,600 [9.0]	3,423	2.62	8.80	8.10
	UGLL-07?BRQ?+RCHJ-48A2	46,000 [13.5]	33,300 [9.8]	12,700 [3.7]	10.50	12.00	7.8	1,600 [755]	48,500 [14.2]	4,156	3.42	31,600 [9.3]	3,734	2.48	8.50	7.80
	UGLL-10?BRM?+RCHJ-48A2	47,000 [13.8]	34,200 [10.0]	12,800 [3.8]	11.30	13.00	7.8	1,600 [755]	47,500 [13.9]	3,888	3.58	30,800 [9.0]	3,471	2.60	8.70	8.05
	UGLL-12?ARM?+RCHJ-48A2	46,500 [13.6]	33,700 [9.9]	12,800 [3.8]	10.85	12.45	7.8	1,600 [755]	48,000 [14.1]	4,019	3.50	31,200 [9.14]	3,600	2.54	8.65	7.90
	UGPL-07?BRQ?+RCHJ-48A2	46,500 [13.6]	33,700 [9.9]	12,800 [3.8]	10.75	12.35	7.8	1,600 [755]	48,000 [14.1]	4,042	3.48	31,400 [9.2]	3,651	2.52	8.60	7.90
	UGPL-10?BRM?+RCHJ-48A2	46,500 [13.6]	33,700 [9.9]	12,800 [3.8]	10.90	12.50	7.8	1,600 [755]	48,000 [14.1]	4,019	3.50	31,200 [9.1]	3,600	2.54	8.65	7.90
	UGPL-12?ARM?+RCHJ-48A2	47,000 [13.8]	34,200 [10.0]	12,800 [3.8]	11.20	13.00	7.8	1,600 [755]	47,500 [13.9]	3,910	3.56	30,800 [9.0]	3,498	2.58	8.70	8.00
060CA/JA	RCBA-6089+RXCT-CHJ	52,500 [15.4]	37,400 [11.0]	15,100 [4.4]	10.00	12.00	7.8	1,950 [920]	58,000 [17.0]	5,247	3.24	36,200 [10.6]	4,653	2.28	7.90	6.85
	RCHJ-60A1 ①	52,500 [15.4]	37,400 [11.0]	15,100 [4.4]	10.00	12.00	7.8	1,950 [920]	58,000 [17.0]	5,247	3.24	36,200 [10.6]	4,653	2.28	7.90	6.85
	UBHK-25+RCBA-6089+RXCT-CHJ	53,000 [15.5]	38,100 [11.2]	14,900 [4.4]	11.00	13.00	7.8	1,950 [920]	53,500 [15.7]	4,479	3.50	35,400 [10.4]	4,183	2.48	8.35	7.40
	UBHK-25+RCHJ-60A1	53,000 [15.5]	38,100 [11.2]	14,900 [4.4]	11.00	13.00	7.8	1,950 [920]	53,500 [15.7]	4,479	3.50	35,400 [10.4]	4,183	2.48	8.35	7.40

① Highest sales volume tested combination required by D.O.E. test procedures.

[] Designates Metric Conversions

BEFORE PURCHASING THIS APPLIANCE, READ IMPORTANT ENERGY COST AND EFFICIENCY INFORMATION AVAILABLE FROM YOUR RETAILER.

GENERAL TERMS OF LIMITED WARRANTY

Ruud will furnish a replacement for any part of this product which fails in normal use and service within the applicable periods stated, in accordance with the terms of the limited warranty.

For Complete Details of the Limited Warranty, Including Applicable Terms and Conditions, See Your Local Installer or Contact the Manufacturer for a Copy.

Condenser Coil leaks caused by

factory defects.....Five (5) Years
Compressor—Three Phase ModelsFive (5) Years
Compressor—Single Phase ModelsTen (10) Years
*Any Other PartFive (5) Years

*This five year limited warranty is applicable only to single-phase products installed in residential applications on or after January 1, 2001.

Electrical and Physical Data

Model Number UPMD-	ELECTRICAL							PHYSICAL						
	Phase Frequency (Hz) Voltage (Volts)	Compressor		Fan Motor Full Load Amperes (FLA)	Minimum Circuit Ampacity Amperes	Fuse or HACR Circuit Breaker		Outdoor Coil			R22 Oz. [g]	Weight		
		Rated Load Amperes (RLA)	Locked Rotor Amperes (LRA)			Minimum Amperes	Maximum Amperes	Face Area Sq. Ft. [m ²]	No. Rows	CFM [L/s]		Net Lbs. [kg]	Shipping Lbs. [kg]	
018JA	1-60-208-230	9.6/9.6	45	.9	13/13	20/20	20/20	11.01 [1.02]	1	2310 [1090]	85 [2410]	160 [72.6]	170 [77.1]	
024JA	1-60-208-230	10.9/10.9	54	1.3	15/15	20/20	25/25	17.26 [1.60]	1	2950 [1392]	115 [3260]	195 [88.5]	205 [93.0]	
030JA	1-60-208-230	12.2/12.2	67	1.3	17/17	20/20	25/25	17.26 [1.60]	1	2950 [1392]	133 [3771]	200 [90.7]	210 [95.3]	
036CA	3-60-208-230	12.1/12.1	77	1.5	17/17	20/20	25/25	16.82 [1.56]	2	3400 [1605]	200 [5670]	205 [93.0]	215 [97.5]	
036JA	1-60-208-230	16.5/16.5	88	1.5	23/23	30/30	35/35	16.82 [1.56]	2	3400 [1605]	200 [5670]	205 [93.0]	215 [97.5]	
042CA	3-60-208-230	12.6/12.6	88	1.5	18/18	25/25	25/25	16.82 [1.56]	2	3400 [1605]	214 [6067]	230 [104.3]	240 [108.9]	
042JA	1-60-208-230	18.6/18.6	109	1.5	25/25	30/30	40/40	16.82 [1.56]	2	3400 [1605]	214 [6067]	230 [104.3]	240 [108.9]	
048CA	3-60-208-230	14.7/14.7	91	1.5	20/20	25/25	30/30	16.82 [1.56]	2	3400 [1605]	214 [6067]	245 [111.1]	255 [115.7]	
048JA	1-60-208-230	19.9/19.9	137	1.5	27/27	35/35	45/45	16.82 [1.56]	2	3400 [1605]	214 [6067]	245 [111.1]	255 [115.7]	
060CA	3-60-208-230	18.4/18.4	123	1.5	25/25	30/30	40/40	22.43 [2.08]	2	3100 [1463]	242 [6861]	305 [138.3]	315 [142.9]	
060JA	1-60-208-230	26.2/26.2	148	1.5	35/35	45/45	60/60	22.43 [2.08]	2	3100 [1463]	242 [6861]	305 [138.3]	315 [142.9]	

Unit Dimensions

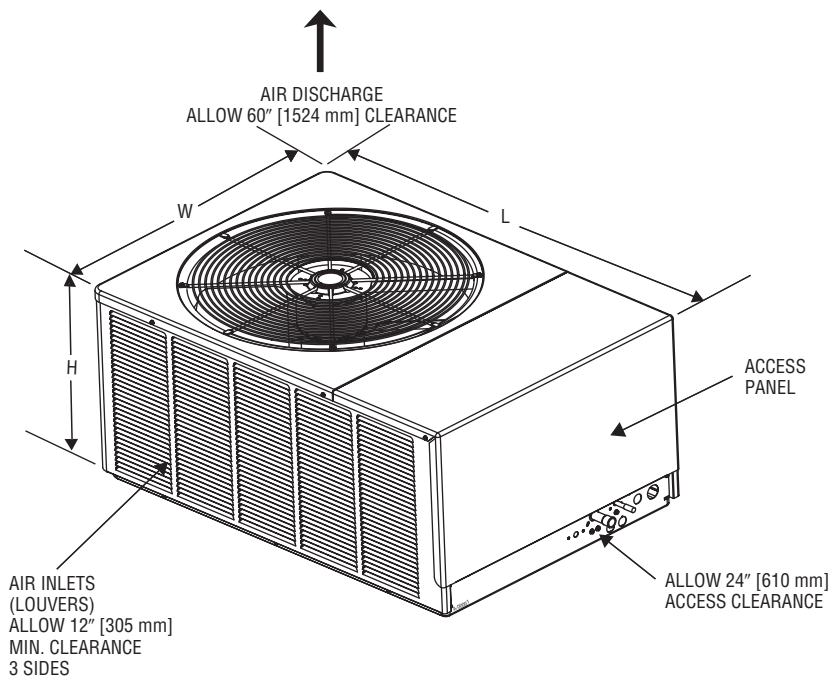

Model Number UPMD-	Height "H" (Inches) [mm]	Length "L" (Inches) [mm]	Width "W" (Inches) [mm]
018	19 [483]	40½ [1029]	27 ⁵ / ₈ [702]
024/030/036 042/048	25 [635]	44 ³ / ₈ [1127]	31½ [800]
060	33 [838]	44 ³ / ₈ [1127]	31½ [800]

[] Designates Metric Conversions

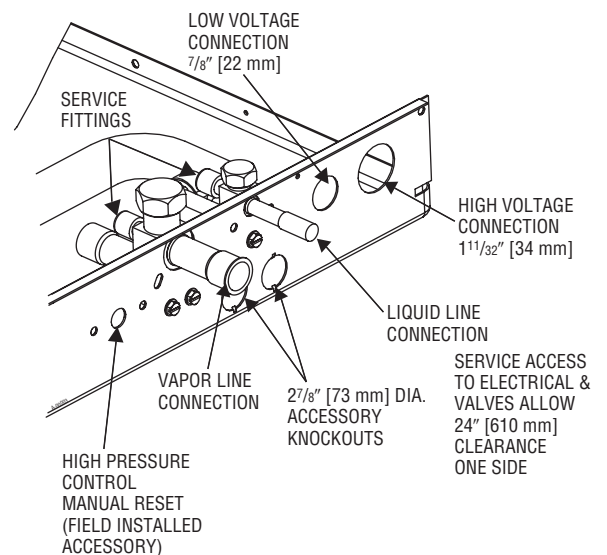

Heat Pump Refrigerant Line Size Information

System Capacity Tons [kW]	Line Size (Inch O.D.) [mm]	Liquid Line Size Outdoor Unit Above Indoor Coil						Liquid Line Size Outdoor Unit Below Indoor Coil						
		Total Length—Feet [m]						Total Length—Feet [m]						
		25 [7.62]	50 [15.24]	75 [22.86]	100 [30.48]	125 [38.10]	150 [45.72]	25 [7.62]	50 [15.24]	75 [22.86]	100 [30.48]	125 [38.10]	150 [45.72]	
		Vertical Separation—Feet [m]						Vertical Separation—Feet [m]						
018	1/4* [6.35]	25 [7.62]	50 [15.24]	70 [21.34]				25 [7.62]	23 [7.01]	8 [2.44]				
	5/16 [7.94]			36 [10.97]	42 [12.80]	48 [14.63]	54 [16.46]			0	0	0	0	
024	1/4* [6.35]	25 [7.62]	50 [15.24]					25 [7.62]	23 [7.01]					
	5/16 [7.94]		24 [7.32]	34 [10.36]	44 [13.41]	54 [16.46]	64 [19.51]		0	0	0	0	0	
030	1/4* [6.35]	25 [7.62]	50 [15.24]					25 [7.62]	23 [7.01]					
	5/16 [7.94]		19 [5.79]	33 [10.06]	47 [14.33]	61 [18.59]			0	0	0	0		
	3/8 [9.53]					11 [3.35]	15 [4.57]							0
036	5/16* [7.94]	25 [7.62]	50 [15.24]	70 [21.34]				25 [7.62]	23 [7.01]	9 [2.74]				
	3/8 [9.53]			34 [10.36]	40 [12.19]	46 [14.02]	52 [15.85]			0	0	0	0	
042	5/16* [7.94]	25 [7.62]	50 [15.24]	75 [22.86]				25 [7.62]	23 [7.01]	9 [2.74]				
	3/8 [9.53]			32 [9.75]	39 [11.89]	46 [14.02]	53 [16.15]			0	0	0	0	
048	3/8* [9.53]	25 [7.62]	44 [13.41]	53 [16.15]	61 [18.59]	70 [21.34]		25 [7.62]	28 [8.53]	19 [5.79]	11 [3.35]	3 [.91]		
	1/2 [12.7]					37 [11.28]	39 [11.89]					0	0	
060	3/8* [9.53]	25 [7.62]	48 [14.63]	61 [18.59]	72 [21.95]			25 [7.62]	23 [7.01]	11 [3.35]	3 [.91]			
	1/2 [12.7]				35 [10.67]	38 [11.58]	41 [12.50]				0	0	0	

*Standard line size

NOTES:

- This chart is applicable for heat pumps.
- If the separation height exceeds the table values, **increase** the outdoor flow-check piston two sizes plus one size for each additional 10 feet [3.05 m].
Example 1: A 5 ton [17.58 kW] *heat pump* with a total line length of 100 feet [30.48 m] with a vertical separation of 93 feet [28.35 m] utilizing a 3/8" [9.53 mm] liquid line: Table = 72 feet [21.95 m] maximum vertical separation for 100 feet [30.48 m] run. Separation exceeds table by (93-72) = 21 feet [6.40 m]. Therefore, reduce the indoor coil flow-check piston 2 + 2 = 4 sizes (For example, a #89 piston would reduce to a #85 piston). Increase the outdoor flow-check piston 2 + 2 = 4 sizes (For example, a #56 would increase to a #60).
- Do not exceed 120 feet [36.58 m] maximum vertical separation.
- No changes are required for expansion valve coils.
- Do not exceed table values for capillary tube coils.
- Always use the smallest liquid line possible to minimize system charge.
- For heat pumps with vertical separation: • Route liquid line outside building • Do not insulate liquid line.
- Chart may be used to size horizontal runs.

NOTES:

- This chart is applicable for heat pumps. Heat pumps with any vertical separation require the use of *standard line sizes* only, due to the possibility of charge imbalance between heating and cooling modes.
Example 1: A 3 ton [10.55 kW] *heat pump* with a total line length of 50 feet [15.24 m] can have a maximum vertical separation of 19 feet [5.79 m]. **Do not increase line size to 3/8" [9.53 mm].**
- This chart may also be used to size horizontal runs.
Example 2: A 1.5 ton [5.28 kW] *heat pump* can have a total *horizontal* line length of 150 feet [45.72 m] when using the 5/16" [7.94 mm] liquid line size. No vertical separation allowed.
- Do not exceed vertical separation as indicated on the chart.
- Always use the smallest liquid line possible to minimize system charge.
- No changes required for flow-check pistons or expansion valve coils.

Vapor Line Length/Size versus Capacity Multiplier									
UPMD-		018	024	030	036	042	048	060	
Unit Vapor Line Connection Size		3/4" [19.05 mm] I.D. Sweat			7/8" [22.23 mm] I.D. Sweat		1 1/8" [28.58 mm] I.D. Sweat*		
Vapor Line Run—Feet [m]		5/8" [15.88 mm] O.D. Optional 3/4" [19.05 mm] O.D. Standard 7/8" [22.23 mm] O.D. Optional			3/4" [19.05 mm] O.D. Optional 7/8" [22.23 mm] O.D. Standard 1 1/8" [28.58 mm] O.D. Optional		7/8" [22.23 mm] O.D. Optional 1 1/8" [28.58 mm] O.D. Standard 1 3/8" [34.93 mm] O.D. Optional		
25' [7.62]	Optional	.98	.98	—	.99	—	.99	.99	
	Standard	1.00	1.00	1.00	1.00	1.00	1.00	1.00	
	Optional	1.01	1.01	1.01	1.01	1.01	1.01	1.01	
50' [15.24]	Optional	.96	.96	—	.97	—	.97	.97	
	Standard	.99	.99	.99	.99	.99	1.00	.99	
	Optional	1.00	1.00	1.00	1.01	1.01	1.01	1.01	
100' [30.48]	Optional	.93	.93	—	.93	—	.96	.95	
	Standard	.99	.98	.97	.98	.98	.99	.99	
	Optional	1.00	.99	.99	1.00	1.00	1.00	1.00	
150' [45.72]	Optional	—	—	—	—	—	.93	.93	
	Standard	.98	.97	.95	.97	.96	.99	.98	
	Optional	1.00	.98	.97	.99	.99	1.00	.99	

NOTES: Capacity Multiplier x Rated Capacity = Actual Capacity.
 Additional compressor oil is not required for runs up to 150 feet [45.72 m].
 Oil traps in vertical runs are not required for any height up to 125 feet [38.10 m]. See Liquid Line chart for Vertical Separation Requirements and Limitations.
 *Adapter to 1 1/8" [28.58 mm] factory supplied.

[] Designates Metric Conversions

Before proceeding with installation, refer to installation instructions packaged with each model, as well as complying with all Federal, State, Provincial, and Local codes, regulations, and practices.

**RUUD
AIR CONDITIONING
DIVISION**

5600 Old Greenwood Road, Fort Smith, Arkansas 72908



"In keeping with its policy of continuous progress and product improvement, Ruud reserves the right to make changes without notice."