

**INSTALLATION & OPERATING
INSTRUCTIONS FOR
UPFLOW/DOWNFLOW COILS**

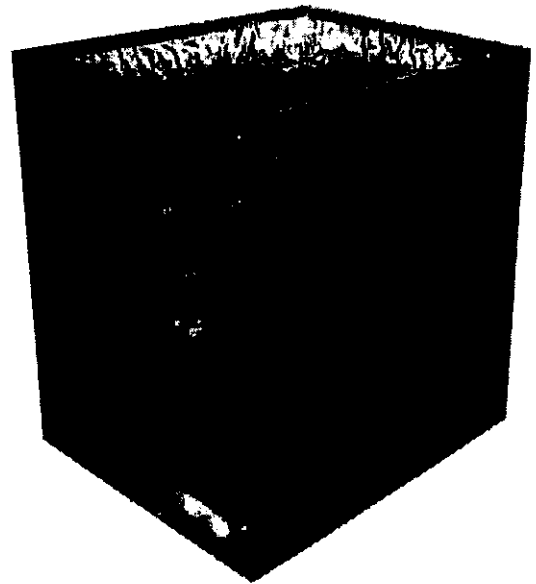
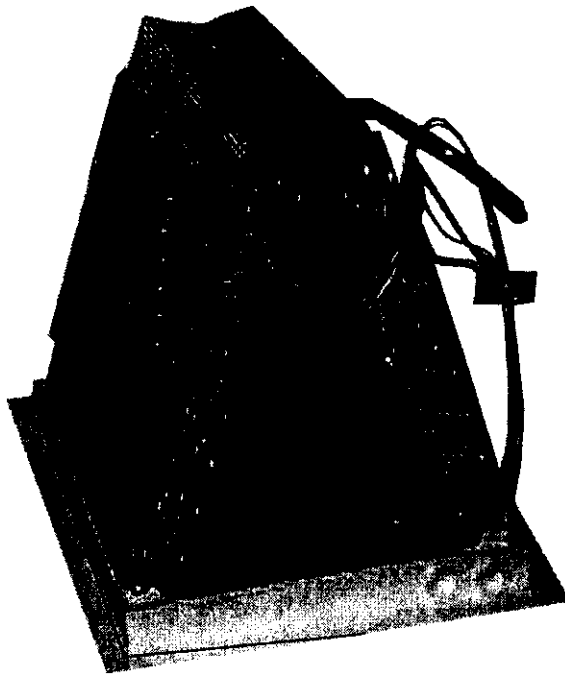

All information contained herein is subject to change without notice.

I0-236A

Made in the USA by:
Goodman Manufacturing Company, L.P.
2550 North Loop West, Suite 400, Houston, TX 77092
www.goodmanmfg.com or amana-hac.com
© 2004 Goodman Manufacturing Company, L.P.

1/04

INDEX

Introduction	2
Replacement Parts	2
Safety Instructions	2
Codes and Regulations	2
Application Information	2
Special Instructions	3
TXV Models	3
Quick Connect Coil Installation of Precharged System	3
Plastic Drain Pan Application	3
Uncased Coil Installation Recommendation	3

INTRODUCTION

Checking Product Received

Upon receiving the product, inspect it for damage from shipment. Claims for damage, either shipping or concealed, should be filed immediately with the shipping company. Check the product to determine if it is correct. In the event an incorrect product is shipped, it must be returned to the supplier and must NOT be installed. The manufacturer assumes no responsibility for installation of incorrectly shipped products.

Before Beginning Installation

Carefully read all instructions for the installation prior to installing product. Make sure each step or procedure is understood and any special considerations are taken into account before starting installation. Assemble all tools, hardware and supplies needed to complete the installation. Some items may need to be purchased locally. Make sure everything needed to install the product is on hand before starting.

REPLACEMENT PARTS

Ordering Parts

When reporting shortages or damages, or ordering repair parts, give the complete product model and serial numbers as stamped on the product. Replacement parts for this product are available through your contractor or local distributor. For the location of your nearest distributor consult the white business pages, the yellow page section of the local telephone book or contact:

SERVICE PARTS DEPARTMENT
GOODMAN MANUFACTURING COMPANY, L.P.
2550 NORTH LOOP WEST, SUITE 400
HOUSTON, TEXAS 77092
(713) 861 - 2500

IMPORTANT SAFETY INSTRUCTIONS

Recognize Safety Symbols, Words, and Labels

The following symbols and labels are used throughout this manual to indicate immediate or potential hazards. It is the owner's responsibility to read and comply with all safety information and instructions accompanying these symbols. Failure to heed safety information increases the risk of serious personal injury or death, property damage and/or product damage.

DANGER

IMMEDIATE HAZARDS WHICH **WILL** RESULT IN PROPERTY DAMAGE, PRODUCT DAMAGE, SEVERE PERSONAL INJURY AND/OR DEATH.

WARNING

HAZARDS OR UNSAFE PRACTICES **COULD** RESULT IN PROPERTY DAMAGE, PRODUCT DAMAGE, SEVERE PERSONAL INJURY AND/OR DEATH.

CAUTION

HAZARDS OR UNSAFE PRACTICES WHICH **MAY** RESULT IN PROPERTY DAMAGE, PRODUCT DAMAGE, AND/OR PERSONAL INJURY.

CODES AND REGULATIONS

IMPORTANT

"The United States Environmental Protection Agency ("EPA") has issued various regulations regarding the introduction and disposal of refrigerants in this unit. Failure to follow these regulations may harm the environment and can lead to the imposition of substantial fines. Because these regulations may vary due to the passage of new laws we suggest that any work on this unit be done by a certified technician. Should you have any questions please contact the local office of the EPA."

This product is designed and manufactured to permit installation in accordance with national codes. It is the installer's responsibility to install this unit in accordance with national codes and/or prevailing local codes and regulations.

APPLICATION INFORMATION

1. Coil must be installed upstream (discharge air) of the furnace.
2. Condensate Drain Piping - In all cooling applications, a secondary drain pan should be provided by the installer and placed under the entire unit with a separate drain line properly sloped and terminated in an area visible to the owner. This secondary drain pan can provide extra protection to the area under the unit should the primary drain plug up and overflow. As expressed in our product warranty, Goodman will not be liable for any damages, structural or otherwise due to the failure to follow this installation requirement.

Condensate drain connections are located in the drain pan at the bottom of the coil/enclosure assembly. The threaded fitting protrudes outside of the enclosure for connecting externally.

1. Drain hole in the drain pan must be clear.
2. Insulate drain line to prevent sweating and dripping. Use armalflex or similar material.

A Secondary Condensate Drain Connection, now called for by many building codes, has been provided. The drain line is to be pitched 1/4" per foot to provide free drainage. A condensate trap should be installed to insure proper drainage.

NOTE: If secondary drain is not installed, the secondary access must be plugged.

PISTON KIT CHART

OUTDOOR SECTION	GOODMAN INDOOR COIL BTU's	INDOOR PISTON SIZE	PISTON KIT PART NO.	OUTDOOR SECTION	GOODMAN INDOOR COIL BTU's	INDOOR PISTON SIZE	PISTON KIT PART NO.		
CKL18-1	18000	.052	(2)	CLJ42-1	42000	.078	(2)		
	24000	.059 TO .052	B17898-52 (3)		48000	.082 TO .078	B17898-78 (1)		
	29000	.059 TO .052	B17898-52 (3)		49000	.082 TO .078	B17898-78 (1)		
	31000	.068 TO .055	B17898-55 (3)		59000	.090 TO .078	B17898-78 (1)		
	32000	.068 TO .055	B17898-55 (3)		60000	.090 TO .078	B17898-78 (1)		
	36000	.071 TO .055	B17898-55 (3)		AE(R)48	.082 TO .078	B17898-78 (1)		
CKL24-1	AH18	.048	(2)	CLJ48-1A	48000	.082	(2)		
	AE(R)24	.062 TO .055	B17898-55 (3)		49000	.082	(2)		
	24000	.059	(2)		59000	.090 TO .082	B17898-82 (1)		
	29000	.059	(2)		60000	.090 TO .082	B17898-82 (1)		
	30000	.065 TO .059	B17898-59 (3)		61000	.090 TO .082	B17898-82 (1)		
	31000	.068 TO .062	B17898-62 (3)		62000	.090 TO .082	B17898-82 (1)		
CKL30-1	32000	.068 TO .062	B17898-62 (3)	CLJ60-1	AE(R)48	.082	(2)		
	36000	.071 TO .062	B17898-62 (3)		59000	.090 TO .093	B17898-93 (1)		
	AE(R)24	.062	(2)		60000	.090 TO .093	B17898-93 (1)		
	29000	0.059 TO .065	(4)		61000	.090 TO .093	B17898-93 (1)		
	30000	.065	(2)		62000	.090 TO .093	B17898-93 (1)		
	31000	.068 TO .065	B17898-65 (3)		AE(R)60	.090 TO .093	B17898-93 (1)		
CKL36-1	32000	.068 TO .065	B17898-65 (3)	CLT24-1A	24000	.059 TO .055	B17898-55 (1)		
	36000	.071 TO .065	B17898-65 (3)		29000	.059 TO .055	B17898-55 (1)		
	42000	.078 TO .068	B17898-68 (3)		31000	.059 TO .055	B17898-55 (1)		
	49000	.082 TO .068	B17898-68 (3)		32000	.059 TO .055	B17898-55 (1)		
	AE(R)30	.068	(2)		36000	.059 TO .055	B17898-55 (1)		
	AE(R)36	.074 TO .068	B17898-68 (3)		42000	.059 TO .055	B17898-55 (1)		
CKL42-1	35000	.071	(2)	CLT30-1	49000	.059 TO .055	B17898-55 (1)		
	36000	.071	(2)		30000	.065	(2)		
	42000	.078 TO .073	B17898-73 (3)		32000	.068 TO .065	B17898-65 (1)		
	49000	.082 TO .073	B17898-73 (3)		36000	.071 TO .065	B17898-65 (1)		
	AE(R)36	.074	(2)		42000	.078 TO .065	B17898-65 (1)		
	CKL48-1/3	42000	.078		(2)	CLT36-1	49000	.082 TO .065	B17898-65 (1)
47000		.082 TO .078	B17898-78 (3)	AE(R)36	.074 TO .065		B17898-65 (1)		
48000		.082 TO .078	B17898-78 (3)	CLT42-1	47000		.082 TO .074	B17898-74 (1)	
49000		.082 TO .078	B17898-78 (3)		48000		.082 TO .074	B17898-74 (1)	
6000		.090 TO .078	B17898-78 (3)		49000		.082 TO .074	B17898-74 (1)	
AE(R)48		.082	(2)		60000		.090 TO .074	B17898-74 (1)	
CKL60-1/3	47000	.082 TO .080	B17898-80 (1)		CLT48-1	AE(R)36	.074	(2)	
	48000	.082 TO .080	B17898-80 (1)			42000	.078	(2)	
	49000	.082 TO .080	B17898-80 (1)	48000		.082 TO .078	B17898-78 (3)		
	59000	.090 TO .080	B17898-80 (1)	49000		.082 TO .078	B17898-78 (3)		
	60000	.090 TO .080	B17898-80 (1)	61000		.090 TO .080	B17898-80 (1)		
	61000	.090 TO .080	B17898-80 (1)	62000		.090 TO .080	B17898-80 (1)		
CKL62-1	AE(R)48	.082	(2)	CLT60-1	AE(R)48	.082	(2)		
	60000	.090	(2)		48000	.082	(2)		
	61000	.090	(2)		49000	.082	(2)		
	62000	.090	(2)		60000	.090 TO .082	B17898-82 (1)		
	AE(R)60	.090	(2)		61000	.090 TO .082	B17898-82 (1)		
	CKL62-1	59000	.090 TO .093		B17898-93 (1)	CLQ24-1	62000	.090 TO .082	B17898-82 (1)
60000		.090 TO .093	B17898-93 (1)	CLQ30-1	AE(R)48		.082	(2)	
61000		.090 TO .093	B17898-93 (1)		31000		.068 TO .065	B17898-65 (1)	
62000		.090 TO .093	B17898-93 (1)		32000		.068 TO .065	B17898-65 (1)	
AE(R)60		.090 TO .093	B17898-93 (1)		36000		.071 TO .065	B17898-65 (1)	
CLJ18-1		18000	.052 TO .055		B17898-55 (1)		CLQ36-1	61000	.090 TO .065
	24000	.059 TO .055	B17898-55 (1)		49000	.082 TO .073		B17898-73 (1)	
	29000	.059 TO .055	B17898-55 (1)	60000	.082 TO .073	B17898-73 (1)			
	30000	.065 TO .055	B17898-55 (1)	61000	.082 TO .073	B17898-73 (1)			
	31000	.068 TO .055	B17898-55 (1)	62000	.082 TO .073	B17898-73 (1)			
	32000	.068 TO .055	B17898-55 (1)	AE(R)36	.082 TO .073	B17898-73 (1)			
CLJ24-1	36000	.071 TO .055	B17898-55 (1)	CLQ42-1	49000	.082 TO .080	B17898-80 (1)		
	AH18	.049 TO .052	B17898-52 (3)		60000	.082 TO .080	B17898-80 (1)		
	AE(R)24	.062 TO .055	B17898-55 (1)		61000	.082 TO .080	B17898-80 (1)		
	CLJ30-1	24000	.059		(2)	CLQ48-1	62000	.082 TO .080	B17898-80 (1)
		30000	.065 TO .059		B17898-59 (1)		49000	.082	(2)
		31000	.068 TO .059		B17898-59 (1)		60000	.090 TO .082	B17898-82 (1)
32000		.068 TO .059	B17898-59 (1)	61000	.090 TO .082		B17898-82 (1)		
29000		.059	(2)	62000	.090 TO .082		B17898-82 (1)		
36000		.071 TO .059	B17898-59 (1)	AE(R)48	.082		(2)		
CLJ36-1	AE(R)24	.062 TO .059	B17898-59 (1)	CLQ60-1	60000	.090	(2)		
	30000	.065	(2)		61000	.090	(2)		
	31000	.068 TO .065	B17898-65 (1)		62000	.090	(2)		
	32000	.068 TO .065	B17898-65 (1)		AE(R)60	.090	(2)		
	36000	.071 TO .065	B17898-65 (1)		CLQ36-1	49000	.082 TO .073	B17898-73 (1)	
	AE(R)30	.068 TO .065	B17898-65 (1)			60000	.082 TO .073	B17898-73 (1)	
AE(R)36	.071 TO .065	B17898-65 (1)	61000	.082 TO .073		B17898-73 (1)			
CLJ36-1	36000	.071	(2)	CLQ42-1		62000	.082 TO .073	B17898-73 (1)	
	42000	.078 TO .073	B17898-73 (1)			49000	.082 TO .080	B17898-80 (1)	
	47000	.082 TO .073	B17898-73 (1)			60000	.082 TO .080	B17898-80 (1)	
	48000	.082 TO .073	B17898-73 (1)		61000	.082 TO .080	B17898-80 (1)		
	AE(R)36	.074	(2)		62000	.082 TO .080	B17898-80 (1)		
	AE(R)36	.074	(2)		AE(R)48	.082 TO .080	B17898-80 (1)		

(1) SUPPLIED WITH OUTDOOR UNIT
 (2) CORRECT PISTON ALREADY PROVIDED ON INDOOR COIL
 (3) PURCHASE PISTON KIT FROM DISTRIBUTOR
 (4) B17898-65 PISTON PROVIDED ON INDOOR COIL
 (5) CORRECT PISTON ALREADY PROVIDED ON OUTDOOR UNIT (AT THE LIQUID SERVICE VALVE)
 NOTE: MOST UNITS ARE SHOWN AS THE ROOT UNIT. BTU'S AND ORIFICE SIZES ARE EQUAL FOR REVISED UNITS, UNLESS OTHERWISE NOTED.

Goodman Manufacturing Company, L.P.
 2550 North Loop West, Suite 400
 Houston, Texas 77092
www.goodmanmfg.com

PISTON KIT CHART (cont'd)

OUTDOOR SECTION	GOODMAN INDOOR COIL BTU's	INDOOR PISTON SIZE	PISTON KIT PART NO.
CPLE18-1	18000	.052	(2)
	24000	.059 TO .052	B17898-52 (3)
	29000	.059 TO .052	B17898-52 (3)
	36000	.071 TO .052	B17898-52 (3)
CPLE24-1	24000	.059	(2)
	29000	.059	(2)
	30000	.065 TO .059	B17898-59 (3)
	31000	.068 TO .059	B17898-59 (3)
	32000	.068 TO .059	B17898-59 (3)
CPLE30-1	29000	.059 TO .065	B17898-65 (3)
	30000	.065	(2)
	31000	.068	(2)
	32000	.068	(2)
	36000	.071 TO .068	B17898-68 (3)
CPLE36-1	49000	.082 TO .068	B17898-68 (3)
	35000	.071 TO .074	B17898-74 (1)
	38000	.071 TO .074	B17898-74 (1)
	42000	.078 TO .074	B17898-74 (1)
	47000	.082 TO .074	B17898-74 (1)
CPLE42-1	48000	.082 TO .074	B17898-74 (1)
	42000	.078	(2)
	47000	.082 TO .078	B17898-78 (3)
	48000	.082 TO .078	B17898-78 (3)
	49000	.082 TO .078	B17898-78 (3)
CPLE48-1	47000	.082	(2)
	49000	.082	(2)
	59000	.090 TO .082	B17898-82 (3)
	60000	.090 TO .082	B17898-82 (3)
	61000	.090 TO .082	B17898-82 (3)
CPLE60-1/3	62000	.090 TO .082	B17898-82 (3)
	61000	.090 TO .092	B17898-92 (1)
CPLJ18-1	18000	.052	(2)
	24000	.059 TO .055	B17898-55 (1)
	32000	.068 TO .055	B17898-55 (1)
	36000	.071 TO .055	B17898-55 (1)
	AE(R)24	.082 TO .055	B17898-55 (1)
CPLJ24-1	24000	.059 TO .065	B17898-65 (1)
	30000	.065	(2)
	31000	.068 TO .065	B17898-65 (1)
	32000	.068 TO .065	B17898-65 (1)
	36000	.071 TO .065	B17898-65 (1)
CPLJ30-1	42000	.078 TO .065	B17898-65 (1)
	42000	.078 TO .068	B17898-68 (1)
	AE(R)30	.068	(2)
	AE(R)36	.074 TO .068	B17898-68 (1)
	CPLJ36-1	36000	.071
42000		.078 TO .074	B17898-74 (1)
49000		.082 TO .074	B17898-74 (1)
AE(R)36		.074	(2)
CPLJ42-1		42000	.078
	49000	.082 TO .078	B17898-78 (1)
	60000	.090 TO .078	B17898-78 (1)
	61000	.090 TO .078	B17898-78 (1)
	AE(R)48	.082 TO .078	B17898-78 (1)
CPLJ48-1	48000	.082	(2)
	49000	.082 TO .084	B17898-84(1)
	60000	.090 TO .084	B17898-84(1)
	61000	.090 TO .084	B17898-84(1)
CPLJ60-1	AE(R)48	.082 TO .084	B17898-84(1)
	60000	.090 TO .089	B17898-89 (1)
	61000	.090 TO .089	B17898-89 (1)
	62000	.090 TO .089	B17898-89 (1)
AE(R)60	.090 TO .089	B17898-89 (1)	

(1) SUPPLIED WITH OUTDOOR UNIT
 (2) CORRECT PISTON ALREADY PROVIDED ON INDOOR COIL
 (3) PURCHASE PISTON KIT FROM DISTRIBUTOR
 (4) B17898-65 PISTON PROVIDED ON INDOOR COIL
 (5) CORRECT PISTON ALREADY PROVIDED ON OUTDOOR UNIT (AT THE LIQUID SERVICE VALVE)
 NOTE: MOST UNITS ARE SHOWN AS THE ROOT UNIT. BTUHS AND ORIFICE SIZES ARE EQUAL FOR REVISED UNITS, UNLESS OTHERWISE NOTED.

OUTDOOR SECTION	GOODMAN INDOOR COIL BTU's	INDOOR PISTON SIZE	PISTON KIT PART NO.
CPLT24-1	32000	.068 TO .062	B17898-62 (1)
	36000	.071 TO .062	B17898-62 (1)
	42000	.078 TO .062	B17898-62 (1)
	AE(R)24	.062	(2)
CPLT30-1	32000	.068 TO .071	B17898-71 (1)
	36000	.071	(2)
	42000	.078 TO .071	B17898-71 (1)
	AE(R)30	.068 TO .071	B17898-71 (1)
CPLT36-1	AE(R)36	.074 TO .071	B17898-71 (1)
	48000	.082 TO .073	B17898-73 (1)
CPLT42-1	49000	.082 TO .073	B17898-73 (1)
	60000	.082 TO .073	B17898-73 (1)
	AE(R)36	.082 TO .073	B17898-73 (1)
CPLT48-1	49000	.082 TO .078	B17898-78 (1)
	60000	.090 TO .078	B17898-78 (1)
	61000	.090 TO .078	B17898-78 (1)
CPLT60-1	AE(R)48	.082 TO .078	B17898-78 (1)
	61000	.090 TO .084	B17898-84 (1)
CPLT60-1	AE(R)60	.082 TO .084	B17898-84 (1)
	61000	.090 TO .092	B17898-92 (1)
AE(R)60	.090 TO .092	B17898-92 (1)	

EXPORT UNITS

CKF36-2/5	36000	.067	(2)
CKF36-2L/5L			
CKF48-5	48000	.076	(2)
CKF48-5L			
CKF60-5	60000	.089	(2)
CKF60-5L	60000	.089	(2)
CKF705L	60000	.089	(2)
CPKF24-2	24000	.059	(2)
CPKF24-2L	24000	.059	(2)
CPKF36-2/5	36000	.067	(2)
CPKF36-2L/5L	36000	.067	(2)
CPKF36-2/5	48000	.078 TO .067	B17898-67(3)
CPKF36-2L/5L	48000	.078 TO .067	B17898-67(3)
CPKF42-5	48000	.076 TO .073	B17898-73 (3)
CPKF42-5L	48000	.076 TO .073	B17898-73 (3)
CPKF48-2	48000	.076	(2)
CPKF48-2L	48000	.076	(2)
CPKF48-5	48000	.076	(2)
CPKF48-5L	48000	.076	(2)
CPKF60-5	60000	.089	(2)
CPKF60-5L	60000	.089	(2)
CPKF61-5	60000	.089 TO .092	B17898-92 (3)
CPKF61-5L	60000	.089 TO .092	B17898-92 (3)

MINI SPLIT UNITS

HDC12-1A	12000	.045	(5)
	18000	.045	(5)
HDC18-1A	18000	.052	(5)
	24000	.052	(5)
HDC24-1A	24000	.055	(5)
HDP12-1A	12000	.045	(5)
	18000	.045	(5)
HDP18-1A	18000	.052	(5)
	24000	.052	(5)
HDP24-1A	24000	.055	(5)

THROUGH THE WALL UNITS

TWC18-1	18000	.052	(2)
TWC24-1	24000	.059	(2)
	30000	.059	B17898-59 (3)
TWCR30-1	36000	.062	B17898-62 (1)

**AMANA PISTON KIT CHART
VALUE LINE BAG ASSY PISTONS**

Mismatched evaporators and Amana condensers will require piston changes as listed below:

OUTDOOR SECTION	PISTON SIZE	PISTON KIT PART NUMBER	OUTDOOR SECTION	PISTON SIZE	PISTON KIT PART NUMBER
VCA18C2*	0.051	2027 2601 (1)	RCC18C2*	0.055	2027 2602 (1)
VCA24C2*	0.059	2027 2603 (1)	RCC24C2*	0.055	2027 2602 (1)
VCA30C2*	0.063	2027 2604 (1)	RCC30C2*	0.063	2027 2604 (1)
VCA36C2*	0.071	2027 2612 (1)	RCC36C2*	0.069	2027 2605 (1)
VCA42C2*	0.076	2027 2607 (1)	RCC42C2*	0.076	2027 2607 (1)
VCA48C2*	0.082	2027 2614 (1)	RCC48C2*	0.084	2027 2608 (1)
VCA60C2*	0.092	2027 2609 (1)	RCC60C2*	0.092	2027 2609 (1)
VCC18C2*	0.051	2027 2601 (1)	RCE24C2*	0.055	2027 2602 (2)
VCC24C2*	0.059	2027 2603 (1)	RCE30C2*	0.063	2027 2604 (2)
VCC30C2*	0.065	2027 2611 (1)	RCE36C2*	0.069	2027 2605 (2)
VCC36C2*	0.072	2027 2606 (1)	RCE42C2*	0.076	2027 2607 (2)
VCC42C2*	0.076	2027 2607 (1)	RCE48C2*	0.084	2027 2608 (2)
VCC48C2*	0.082	2027 2614 (1)	RCE60C2*	0.092	2027 2609 (2)
VCC60C2*	0.092	2027 2609 (1)			
VHA18C2*	0.055	2027 2602 (1)	RHA18C2*	0.055	2027 2602 (2)
VHA24C2*	0.063	2027 2604 (1)	RHA24C2*	0.063	2027 2604 (2)
VHA30C2*	0.065	2027 2611 (1)	RHA30C2*	0.065	2027 2611 (2)
VHA36C2*	0.071	2027 2612 (1)	RHA36C2*	0.069	2027 2605 (2)
VHA42C2*	0.076	2027 2607 (1)	RHA42C2*	0.074	2027 2607 (2)
VHA48C2*	0.084	2027 2608 (1)	RHA48C2*	0.084	2027 2608 (2)
VHA60C2*	0.092	2027 2609 (1)	RHA60C2*	0.090	2027 2616 (2)
VHC18C2*	0.055	2027 2602 (1)	RHE18C2*	0.055	2027 2602 (2)
VHC24C2*	0.065	2027 2611 (1)	RHE24C2*	0.065	2027 2611 (2)
VHC30C2*	0.065	2027 2611 (1)	RHE30C2*	0.069	2027 2605 (2)
VHC36C2*	0.076	2027 2607 (1)	RHE36C2*	0.076	2027 2607 (2)
VHC42C2*	0.078	2027 2617 (1)	RHE42C2*	0.082	2027 2614 (2)
VHC48C2*	0.084	2027 2608 (1)	RHE48C2*	0.092	2027 2609 (2)
VHC60C2*	0.092	2027 2609 (1)	RHE60C2*	0.098	2027 2610 (2)
RCB18C2*	0.053	2027 2613 (1)	RHF24C2*	0.055	2027 2602 (2)
RCB24C2*	0.059	2027 2603 (1)	RHF30C2*	0.063	2027 2604 (2)
RCB30C2*	0.065	2027 2611 (1)	RHF36C2*	0.069	2027 2605 (2)
RCB36C2*	0.071	2027 2612 (1)	RHF42C2*	0.076	2027 2607 (2)
RCB42C2*	0.076	2027 2607 (1)	RHF48C2*	0.084	2027 2608 (2)
RCB48C2*	0.084	2027 2608 (1)			
RCB60C2*	0.092	2027 2609 (1)			

(1) SUPPLIED WITH THE OUTDOOR UNIT.

(2) PURCHASE PISTON KIT FROM THE DISTRIBUTOR.

SPECIAL INSTRUCTIONS

This indoor coil contains the flowrate distributor assembly, which consists of a flare nut, distributor body, copper tubes feeding the coil, and the internal flow check piston. It is essential that the indoor and outdoor sections be properly matched. When matching the indoor coil with other than the matching outdoor section, the flow check piston in the indoor section should be changed to match the outdoor section to obtain rated performance as specified in our sales specification sheets. (See Piston Kit Chart - PKC-00R).

A piston size that is too small will cause starving and one that is too large will cause flooding. If a combination is used that requires a piston size change, the piston in the distributor on the indoor coil before installing the coil and charging the system following the procedure shown below.

1. Using a back-up wrench on the flare fitting, remove the 3/8" flare nut.
2. Using a back-up wrench on the distributor body, remove the 3/8" flare fitting and Teflon seal.
3. Using the wire provided with replacement pistons, run wire (hooked end) through hole in piston.
4. Hook nose end of piston and lift gently from distributor body.
5. Referring to the Piston Kit Chart, replace piston with one of proper size.
6. Install piston with Teflon seal end of piston in distributor first. Do not force piston into distributor.

NOTE: With piston in distributor, seal end should be down and should not be seen looking in end of distributor. Piston must be free to rotate and move up and down. Make sure piston is free to move in distributor body.

7. Replace 3/8" flare fitting with Teflon seal using back-up wrench on distributor body. Torque fitting with 8 to 10 ft. lb. Do not over tighten.
8. Replace 3/8" flare nut using back-up wrench on flare fitting. Torque 3/8" flare nut with 40 to 45 ft. lb.
9. Remove old piston size label from outside of distributor body.
10. Remove new piston size label from the poly bag the new piston came in and install new size label on outside of distributor.
11. Check fittings for leaks after installation, and make sure evacuation and charging of low side are complete.

TXV MODELS

Installation Note

The TXV bulb is permanently secured at the factory. To prevent damage, remove the bulb when welding and attach/insulate to the suction line after welding. For the majority of installation, no adjustment to the TXV setting is required. However, if the measured superheat is less than 8° or greater than 20° an adjustment is required. The adjustment stem is at the base of the valve (opposite the diaphragm) under a flair nut. To increase the superheat when measured at the condenser base valve, turn the stem clockwise (⤵). Similarly to decrease the superheat, turn the stem counterclockwise (⤴). Use a 1/4" refrigeration wrench for this function.

NOTE FOR QUICK CONNECT COILS INSTALLATION OF PRECHARGED SYSTEM

A brief description follows, for specific instructions refer to the Condensing Unit's Installation and Operating Instructions.

1. Connect lines to evaporator coil before connecting to the condensing units.
 - A. Form tubing so it properly aligns with coil connections.
 - B. Remove plugs and caps from connections.
 - C. Check to be sure mating surfaces are clean.
 - D. Lubricate rubber seal with clean refrigerant oil and thread couplings together by hand to be sure they are not cross threaded.
 - E. Tighten connections using backup wrench on evaporator quick connect fitting until coupling bottoms; then tighten 1/6 turn to complete knife edge seal.
2. Connect lines to condensing unit in the same manner as to evaporator coil. Observe same precautions.
3. After making all connections and opening valves, check all piping for leaks.

PLASTIC DRAIN PAN APPLICATION



WARNING

DO NOT USE ANY OTHER DRAIN PAN, PLASTIC OR METAL, ON THE UPFLOW/DOWNFLOW COIL OTHER THAN THE WHITE PLASTIC ONE LABELED AS PART NO. BT50765XX. THIS IS THE ONLY DRAIN PAN DESIGNED TO BE PLACED ON THE TOP OF A GAS FURNACE. FAILURE TO FOLLOW THIS WARNING MAY RESULT IN PROPERTY DAMAGE AND/OR PERSONAL INJURY.

If you install your cased/uncased coil on top of a gas furnace the following is required:

Allow enough space between the top to the furnace heat exchanger and the bottom of the plastic coil drain pan to have a free flow of air.

There should be a minimum of 2.0" distance from the sectional heat exchanger and the bottom of the pan. See figure 1.

UNCASED COIL INSTALLATION RECOMMENDATIONS:

Minimum distance between furnace and coil pan: 2".

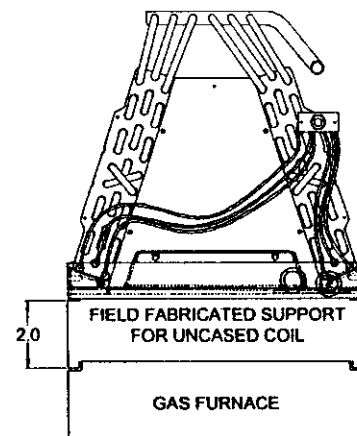

FIGURE 1