

Air Handler Heat Pump System

Location:	Approval:
Engineer:	Date:
Submitted to:	Construction:
Submitted by:	Unit #:
Reference:	Drawing #:

System Product Code: 810175550091
Indoor Unit Product Code: 810175550077
Outdoor Unit Product Code: 810175550084



INDOOR UNIT SPECIFICATIONS

Indoor Air Flow (Turbo/H/M/L/Si) (CFM)	618.03 / 576.83 / 529.74 / 488.54 / NA	
Indoor Noise Level (Turbo/H/M/L/Si) (dBA)	44 / 43 / 41 / 33 / NA	
Dimension (W×D×H)	inch	17.52 x 21.02 x 45.00
	mm	445.0 x 534.0 x 1143.0
Package (W×D×H)	inch	26.57 x 20.87 x 48.62
	mm	675 x 530 x 1235
Net/Gross Weight	lbs	105.82 / 126.76
	kg	48 / 57.5

OUTDOOR UNIT SPECIFICATIONS

Compressor Type	ROTARY	
Compressor Model	KSN140D58UFZ	
Refrigerant	R454B	
Refrigerant Oil Charge (mL)	440	
Refrigerant Oil	VG74	
Outdoor Air Flow (Max) (CFM)	1450.9	
Outdoor Noise Level (dBA)	55	
Dimension (W×D×H)	inch	31.69 x 12.99 x 21.81
	mm	805.0 x 330.0 x 554.0
Package (W×D×H)	inch	36.02 x 14.57 x 24.21
	mm	915 x 370 x 615
Net/Gross Weight	lbs	77.16 / 83.77
	kg	35 / 38

EFFICIENCY RATINGS

Cooling		Heating	
SEER2	21.0	HSPF2-4	10.0
EER2	12.5	COP	3.87

COOLING PERFORMANCE

Cooling (Btu/hr)	
Rated Capacity	12000
Min/Max Capacity	5300~15000
Moisture Removal (L/h)	1.71
Standard Operating Range (*F/C)	-13~122 (-25~50)
Rated Cooling Conditions:	Indoor: 80°F DB/67°F WB Outdoor: 95°F DB/75°F WB

HEATING PERFORMANCE

Heating (Btu/hr)	
1. @ 47°F Rated	13000
2. @ 47°F Min/Max Capacity	5600~19000
3. @ 17°F Rated	12600
4. @ 5°F Rated: Capacity / COP	11200 / 2
5. @ 5°F Max: Capacity	11200
Standard Operating Range (*F/C)	-13~75 (-25~24)
1. Rated Heating Conditions:	Indoor: 70°F DB/60°F WB Outdoor: 47°F DB/43°F WB
2. Rated Heating Conditions:	Indoor: 70°F DB/60°F WB Outdoor: 17°F DB/15°F WB
3. Heating Conditions, Compressor Operating at Max. Frequency	Indoor: 70°F DB/60°F WB Outdoor: 5°F DB/5°F WB

ELECTRICAL SPECIFICATIONS

Indoor Power Supply	115/208/230V, 60Hz, 1Ph
Indoor MCA 115V/(208/230V)	5.5 / 4.0
Indoor MOP	15
Outdoor Power Supply	208/230V, 60Hz, 1Ph
Outdoor MCA	16
Outdoor MOP	20
Communication Wiring	AWG 20-2
Compressor RLA	10
Outdoor Fan Motor RLA	0.8
Outdoor Fan Motor W	34
Indoor Fan Motor RLA	2
Indoor Fan Motor W	250
System Power Input @ Cooling (W)	960 (400 ~ 1900)
System Power Input @ Heating (W)	909 (340 ~ 1650)
MCA: Min. circuit amps (A)	MOP: Max. overcurrent protection (A)
RLA: Rated load amps (A)	W: Fan motor rated output (W)

REFRIGERANT PIPING SPECIFICATIONS

Throttle type (Indoor)	EXV
Throttle type (Outdoor)	EXV
Liquid Size	9.52 mm (3/8 in)
Gas Size	19 mm (3/4 in)
Max. Piping Length (ft/m)	98.4 (30)
Max. Height Difference (ft/m)	65.6 (20)
Max. Pre-charged Length (ft/m)	24.6 (7.5)
Refrigerant Pre-charged Amount (oz/kg)	51.15 (1.45)
Additional Charge of Refrigerant ((oz/ft)/(g/m))	0.7 (65)
Connection Method	Flared*

*The gas valve of the outdoor unit is 5/8", 5/8" to 3/4" flare to flare connector is required for the installation.

Indoor Unit Dimensions

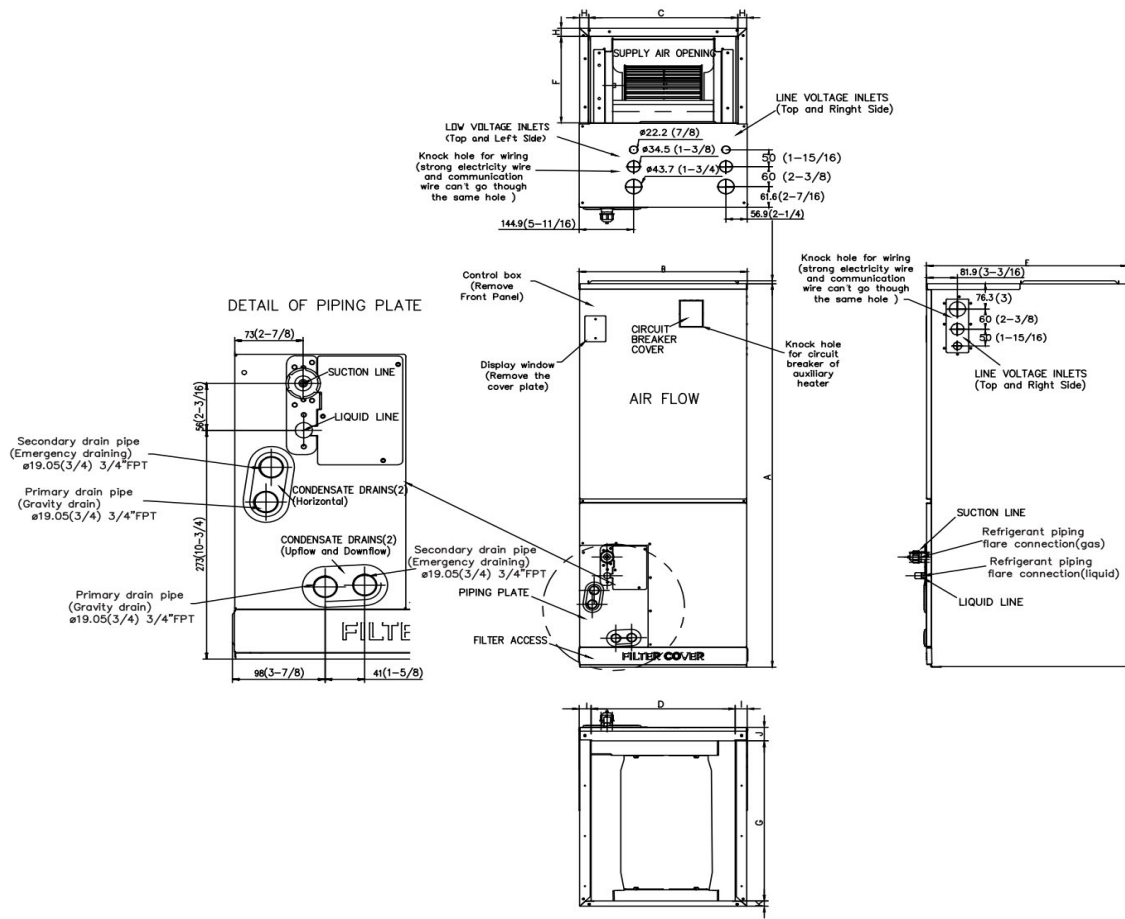

Dimensions	Model	18k/24k		30k/36k		48k/60k	
		inch	mm	inch	mm	inch	mm
A	Model Height	45	1143	49	1245	53	1346
B	Model Width	17-1/2	445	21	534	24-1/2	622
C	Supply Air Opening Width	15-5/8	397	19-1/8	486	22-5/8	575
D	Return Air Opening Width	15-1/8	384	18-5/8	473	22-1/8	562
E	Model Depth	21	534	21	534	21	534
F	Supply Air Opening Depth	10-1/4	260	10-1/4	260	10-1/4	260
G	Return Air Opening Depth	18-3/4	476	18-3/4	476	18-3/4	476
H	Supply Air Opening Clearance	15/16	24	15/16	24	15/16	24
I	Return Air Opening Side Clearance	1-1/4	32	1-1/4	32	1-1/8	28
J	Return Air Opening Front Clearance	1-1/2	38	1-5/8	41	1-5/8	41
K	Return Air Opening Back Clearance	5/8	16	5/8	16	3/4	19

Outdoor Unit Dimensions

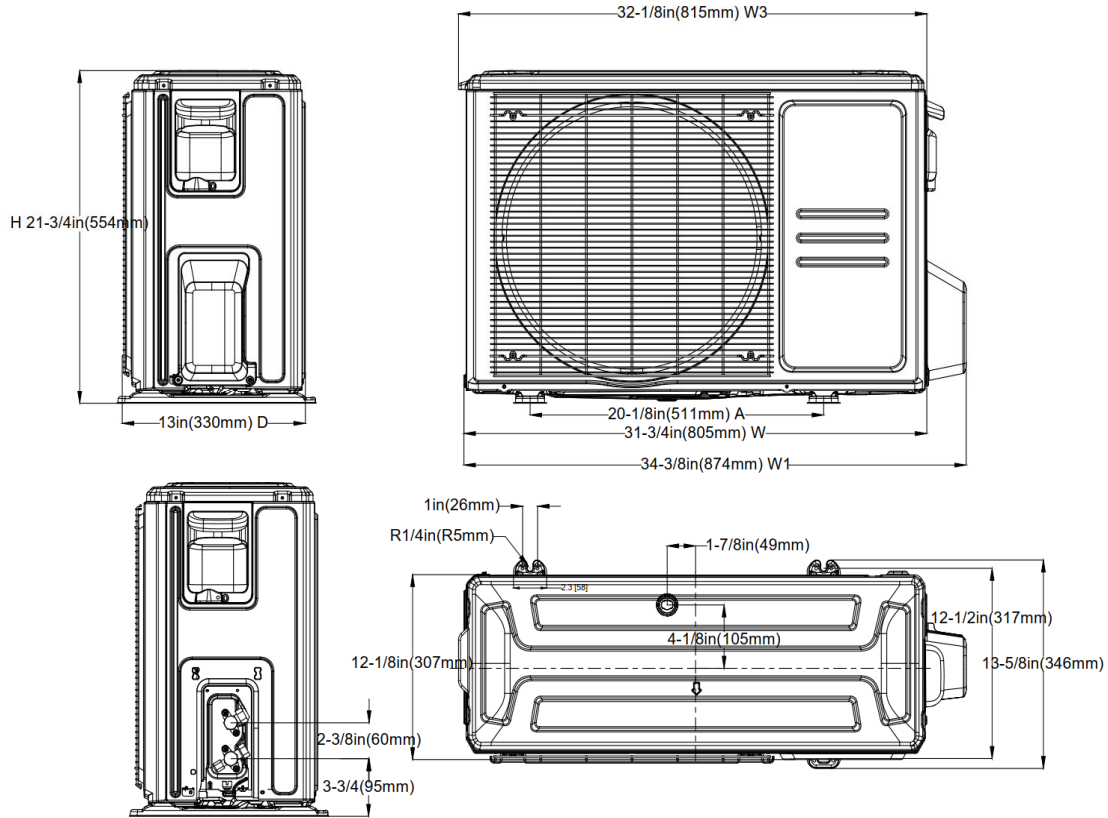

Installation Instructions for Outdoor Unit

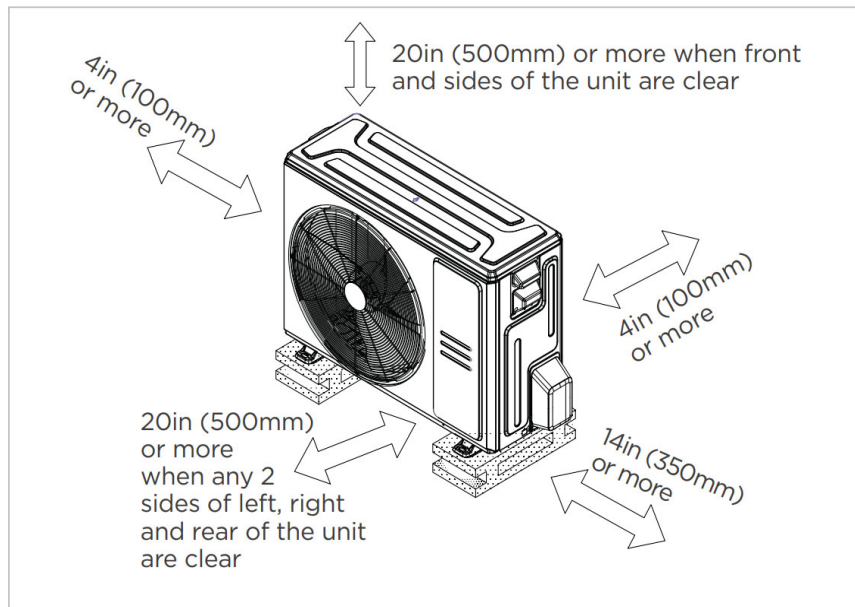

Meets all spatial requirements shown in Installation Clearance Requirements above.

Fan Performance For Indoor Unit

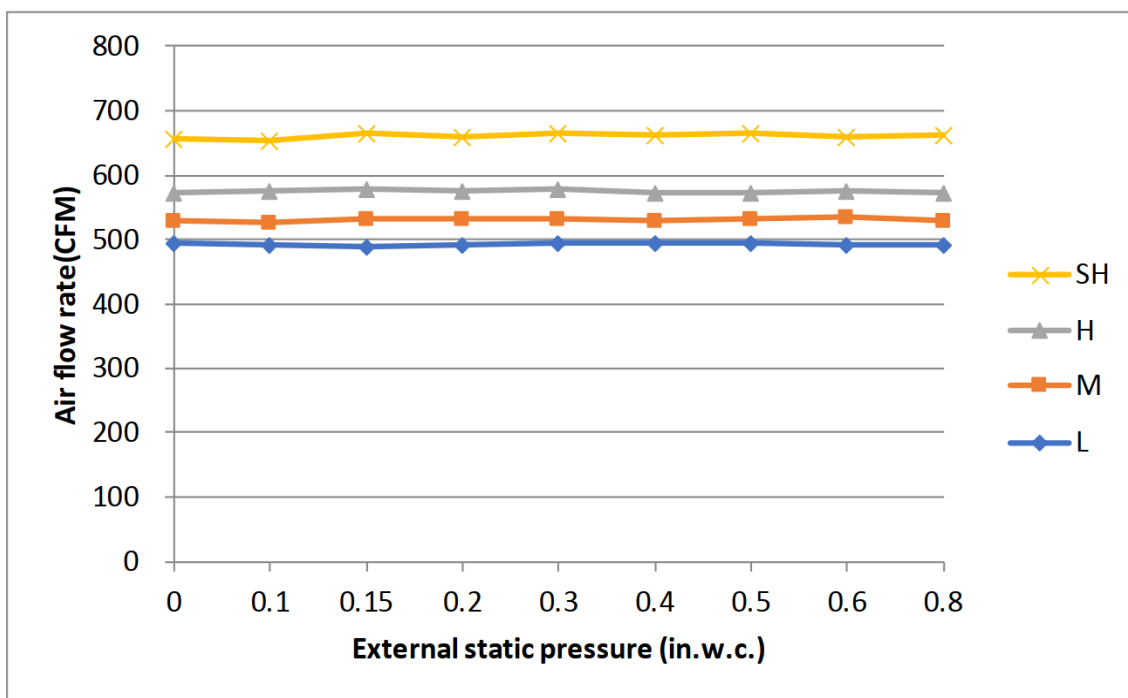

Features

- Multi-position installation: horizontal (left or right), vertical (up or down)
- Aluminum Coil
- Constantly Air Flow system up to 0.80 In.W.G
- 1 inch R4.2 fiberglass free insulation reduces condensation and boosts efficiency (optional)
- Optional Auxiliary heat kit up to 25kW
- Easy Maintenance
- Multiple control options available:
 - Two way communication wired controller:120N(X6)
 - Two way communication wired controller with built-in WiFi:120N(X6W)
 - Wireless remote controller
 - Third-Party 24V Thermostat
- Adaptive Control System
- High efficiency up to 21 SEER2, 12.5 EER2, 10 HSPF2
- Chassis heater and crankcase heater equipped as standard