

**SUBMITTAL DATA: CAS12HP230V1BC****12000 BTU/H Cassette**

Job Name	Location	Date
Purchaser	Engineer	
Submitted To	For	
Unit Designation	Schedule No.	

**YT1F****CAS12HP230V1BC****XK19****GENERAL FEATURES**

**AHRI Certificate: See Matching or Paired Outdoor Unit AHRI Certificate**

**Compact and Quiet Design**

**4 - Way Discharge Air**

**Internal Condensate Drain Pump**

**Wireless Remote with LCD Display Included**

**XK19 Wired Controller Included**

**Low Ambient Cooling Based on Outdoor Unit Performance**

**Low Ambient Heating Based on Outdoor Unit Performance**

**Copper Tube / Aluminum Fin Coil (Blue Fin) 500 Hrs Salt Spray Tested**

**5 Year Limited Compressor & Parts Warranty (Residential Only)**

SPECIFICATIONS		CAS12HP230V1BC	
System Type		HEAT PUMP	
<b>SYSTEM PERFORMANCE</b>			
Cooling	Rated Capacity @ 95°F	Btu/h	See Outdoor Unit Submittals -Connected Unit Capacities
	Min-Max Capacity	Btu/h	900 - 14100
Heating	Rated Capacity @ 47°F	Btu/h	See Outdoor Unit Submittals -Connected Unit Capacities
	Min-Max Capacity	Btu/h	900 - 15500
SEER / EER		Based on Outdoor Unit Performance	
HSPF / COP		Based on Outdoor Unit Performance	
Energy Star®		Based on Outdoor Unit Performance	
Cooling Temperature Range		°F	Based on Outdoor Unit Performance
Heating Temperature Range		°F	Based on Outdoor Unit Performance
<b>INDOOR UNIT</b>		<b>CAS12HP230V1BC</b>	
Fan Motor Output Power		W	45
Fan Motor FLA		amps	0.5
Air Flow (Min - Max)		CFM	265 - 383
Sound Pressure Level (Cooling / Heating)		dB(A)	34 -44
Dehumidification		pt/hr	2.96
Condensate Drain Size (OD)		in	1
Unit Dimension (WxHxD)		in	23 1/2 X 23 1/2 X 9 1/2
Package Dimension (WxHxD)		in	30 1/2 X 29 X 11 1/4
Weight (Net / Gross)		lbs	44 /53
<b>REFRIGERANT PIPING</b>			
Line Set Size (Liquid - Gas)		in	1/4 - 3/8
Pre-Charge Length		ft	Based on Outdoor Unit
Pipe Length (Min - Max)		ft	Based on Outdoor Unit
Max. Pipe Elevation		ft	Based on Outdoor Unit
<b>ELECTRICAL</b>			
Power Supply (Voltage Operating Range)		Powered by Outdoor Unit	
Rated Current (Cooling / Heating)		amps	Based on Outdoor Unit
MCA / MOCP		amps	Based on Outdoor Unit
Main Power Wire Size		AWG	Size Per Local Code
Interconnecting Wire Size		AWG	14 / 4
<b>LIMITED WARRANTY</b>		<b>5 Years Residential</b>	

REMOTE CONTROLLER FUNCTIONS	
Auto Mode	Yes
Auto Fan	Yes
Auto Swing (Horizontal Auto Swing)	No
Auto Swing (Vertical Auto Swing)	Yes
Clock	Yes
Dry Mode	Yes
Dry Anti-Mildew (X-Fan) Mode	Yes
Energy Saving Mode	Yes
Dirty Filter Alert	No
Fan Speed Control (7 Speeds)	Yes
I Feel Function	Yes
Privacy Lock	Yes
Quiet Mode	No
Room Temperature Display	No
Sleep Mode	Yes
Normal Sleep Mode Option	Yes
Timer Mode	Yes
Turbo Mode	Yes
Display On/Off Control	Yes
Freeze Guard Mode	Yes
Power Failure Mode	Yes

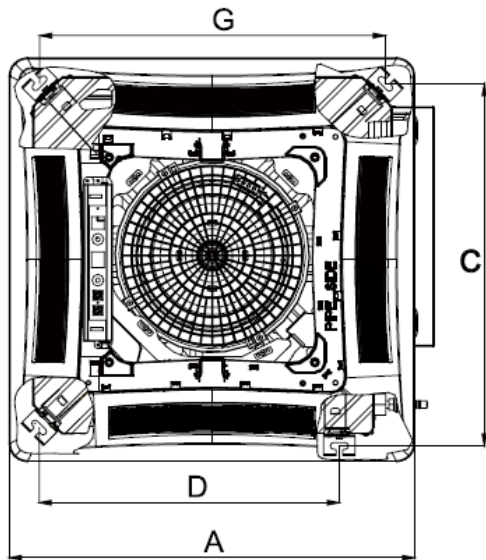

Dimensions	
A	26 3/8
B	26 3/8
C	23 5/8
D	19 1/2
E	5 11/16
F	9 7/16
G	23 1/2

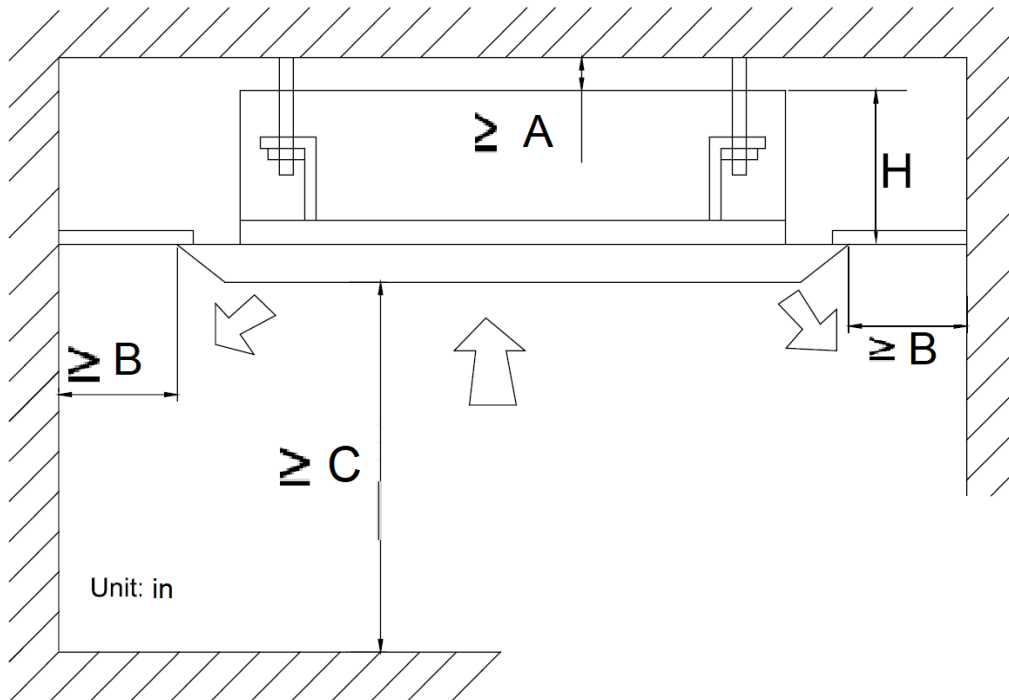
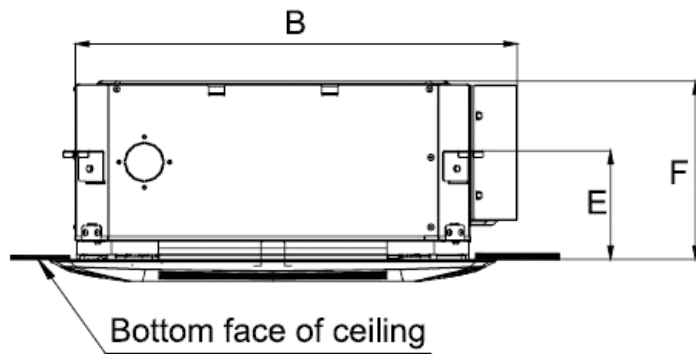

Clearances	
A	7/8
B	60
C	98
H	10

Unit: in