

MSZ-FS18NA & MUZ-FS18NA
18,000 BTU/H DELUXE WALL-MOUNTED INDOOR UNIT
18,000 BTU/H HYPER-HEATING OUTDOOR UNIT



Job Name:

System Reference:

Date:



Indoor Unit.....MSZ-FS18NA

Outdoor Unit.....MUZ-FS18NA



INDOOR UNIT FEATURES

- Slim wall-mounted indoor units provide zone comfort control
- Dual Barrier Coating applied to the heat exchanger, vanes and fan to prevent hydrophilic and hydrophobic dirt build-up
- Multiple fan speed options: Quiet, Low, Medium, High, Super-high, Auto
- 3D i-see Sensor® enables advance features:
 - Indirect or Direct Airflow for personalized comfort
 - Absence Detection for energy-saving mode
- Double Vane features:
 - Separates airflow to deliver air across a large area
 - Simultaneously deliver to air separate sections of a room
 - Generates more comfortable natural airflow pattern
- Multiple control options available:
 - Back-lit screen handheld remote controller (provided with unit)
 - kumo cloud® smart device app for remote access
 - Third-party interface options
 - Wired or wireless controllers
- Triple-action Filtration: Nano Platinum Filter, Deodorizing Filter, & Electrostatic Anti-Allergy Enzyme Filter
- Hot-Start Technology: no cold air rush at equipment startup or when restarting after Defrost Cycle
- Quiet operation

OUTDOOR UNIT FEATURES

- INVERTER-driven compressor and LEV provide high efficiency and comfort while using only the energy needed to maintain maximum performance
- H2i plus™ performance offers 100% heating capacity at -5° and 70% to 81% heating capacity at -13° F
- Blue Fin anti-corrosion treatment applied to the outdoor unit heat exchanger for increased coil protection and longer life

SPECIFICATIONS: MSZ-FS18NA & MUZ-FS18NA

Cooling at 95°F ¹	Maximum Capacity	BTU/H	21,000
	Rated Capacity	BTU/H	17,200
	Minimum Capacity	BTU/H	6,450
	Maximum Power Input	W	2,220
	Rated Power Input	W	1,375
	Moisture Removal	Pints/h	4.8
	Sensible Heat Factor		0.69
Heating at 47°F ²	Maximum Capacity	BTU/H	30,000
	Rated Capacity	BTU/H	19,000
	Minimum Capacity	BTU/H	5,150
	Maximum Power Input	W	4,000
	Rated Power Input	W	1,610
	Power Factor [208V / 230V]	%	98.0 / 98.0
Heating at 17°F ³	Maximum Capacity	BTU/H	27,000
	Rated Capacity	BTU/H	12,800
	Maximum Power Input	W	3,700
	Rated Power Input	W	1,160
Heating at 5°F ⁴	Maximum Capacity	BTU/H	23,000
	Maximum Power Input	W	3,130
Heating at -5°F ⁶	Maximum Capacity	BTU/H	19,000
Heating at -13°F ⁷	Maximum Capacity	BTU/H	17,100
Efficiency	SEER		21.0
	EER ¹		12.5
	HSPF [IV]		12.5
	COP at 47°F ²		3.46
	COP at 17°F at Maximum Capacity ³		2.14
	COP at 5°F at Maximum Capacity ⁴		2.0
	COP at -5°F at Maximum Capacity ⁶		2.0
	COP at -13°F at Maximum Capacity ⁷		2.0
	ENERGY STAR® Certified		Yes
Electrical	Voltage, Phase, Frequency		208/230, 1, 60
	Guaranteed Voltage Range	V AC	187 - 253
	Voltage: Indoor - Outdoor, S1-S2	V AC	208/230
	Voltage: Indoor - Outdoor, S2-S3	V DC	24
	Short-circuit Current Rating [SCCR]	kA	5
	Recommended Fuse/Breaker Size (Outdoor)	A	20
	Recommended Wire Size [Indoor - Outdoor]	AWG	14
	Power Supply		Indoor unit is powered by the outdoor unit
Indoor Unit	MCA	A	1.0
	Fan Motor Full Load Amperage	A	0.65
	Fan Motor Type		DC Motor
	Airflow Rate at Cooling, Dry	CFM	225-262-304-355-437
	Airflow Rate at Cooling, Wet	CFM	194-225-261-305-376
	Airflow Rate at Heating, Dry	CFM	201-272-350-410-514
	Sound Pressure Level [Cooling]	dB[A]	27-31-35-39-44
	Sound Pressure Level [Heating]	dB[A]	25-31-37-40-46
	Drain Pipe Size	In. [mm]	5/8 [15.88]
	Coating on Heat Exchanger		Dual Barrier Coating
	External Finish Color		Munsell 1.0Y 9.2/0.2
	Unit Dimensions	W x D x H: In. [mm]	36-7/16 x 9-3/16 x 12 (+11/16) [925 x 234 x 305 (+17)]
	Package Dimensions	W x D x H: In. [mm]	39 x 12-1/4 x 15-1/2 [990 x 310 x 400]
	Unit Weight	Lbs. [kg]	29 [13.5]
Package Weight	Lbs. [kg]	34 [15.4]	
Indoor Unit Operating Temperature Range	Cooling Intake Air Temp [Maximum / Minimum]*	°F	90 DB, 73 WB / 67 DB, 57 WB
	Heating Intake Air Temp [Maximum / Minimum]	°F	80 DB / 70 DB

NOTES:

AHRI Rated Conditions

(Rated data is determined at a fixed compressor speed)

¹Cooling (Indoor // Outdoor) °F 80 DB, 67 WB // 95 DB, 75 WB

²Heating at 47°F (Indoor // Outdoor) °F 70 DB, 60 WB // 47 DB, 43 WB

³Heating at 17°F (Indoor // Outdoor) °F 70 DB, 60 WB // 17 DB, 15 WB

Conditions

⁴Heating at 5°F (Indoor // Outdoor) °F 70 DB, 60 WB // 5 DB, 4 WB

⁶Heating at -5°F (Indoor // Outdoor) °F 70 DB, 60 WB // -5 DB, -6 WB

⁷Heating at -13°F (Indoor // Outdoor) °F 70 DB, 60 WB // -13 DB, -14 WB

*Indoor/Outdoor Unit Operating Temperature Range (Cooling Air Temp [Maximum / Minimum]):

- Applications should be restricted to comfort cooling only; equipment cooling applications are not recommended for low ambient temperature conditions.

**Outdoor Unit Operating Temperature Range (Cooling Thermal Lock-out / Re-start Temperatures; Heating Thermal Lock-out / Re-start Temperatures):

- System cuts out in heating mode to avoid thermistor error and automatically restarts at these temperatures.

SPECIFICATIONS: MSZ-FS18NA & MUZ-FS18NA

Outdoor Unit	MCA	A	18.0	
	MOCP	A	20	
	Fan Motor Full Load Amperage	A	0.93	
	Fan Motor Output	W	50	
	Airflow Rate [Cooling / Heating]	CFM	1801 / 1949	
	Refrigerant Control		LEV	
	Defrost Method		Reverse Cycle	
	Coating on Heat Exchanger		Blue Fin Coating	
	Sound Pressure Level, Cooling ¹	dB(A)	52	
	Sound Pressure Level, Heating ²	dB(A)	55	
	Compressor Type		Twin Rotary	
	Compressor Model		SNB172FQKMT	
	Compressor Rated Load Amps	A	17	
	Compressor Locked Rotor Amps	A	13.6	
	Compressor Oil [Type // Charge]	oz.	FV50S // 0.40	
	External Finish Color		Munsell 3Y 7.8/1.1	
	Base Pan Heater		Optional	
	Unit Dimensions	W x D x H: In. [mm]	33-1/16 x 13 x 34-5/8 [840 x 330 x 880]	
	Package Dimensions	W x D x H: In. [mm]	38-3/4 x 16-3/4 x 39 [980 x 420 x 990]	
	Unit Weight	Lbs. [kg]	118 [53.5]	
	Package Weight	Lbs. [kg]	134 [60.5]	
	Outdoor Unit Operating Temperature Range	Cooling Air Temp [Maximum / Minimum]*	°F	115 DB / 14 DB
		Cooling Thermal Lock-out / Re-start Temperatures**	°F	-4 / 0
Heating Air Temp [Maximum / Minimum]		°F	75 DB, 65 WB / -13 DB, -14 WB	
Heating Thermal Lock-out / Re-start Temperatures**		°F	-18 / -14	
Refrigerant	Maximum Charge Quantity	Lbs, oz	3.0, 7.0	
	Initial Charge Quantity	Ft. [m]	25.0 [7.5]	
	Additional Refrigerant Charge Per Additional Piping Length	oz./Ft. [g/m]	0.216 [20]	
Piping	Gas Pipe Size O.D. [Flared]	In.[mm]	1/2 [12.7]	
	Liquid Pipe Size O.D. [Flared]	In.[mm]	1/4 [6.35]	
	Maximum Piping Length	Ft. [m]	100 [30]	
	Maximum Height Difference	Ft. [m]	50 [15]	
	Maximum Number of Bends		10	

NOTES:

AHRI Rated Conditions	¹ Cooling (Indoor // Outdoor)	°F	80 DB, 67 WB // 95 DB, 75 WB
(Rated data is determined at a fixed compressor speed)	² Heating at 47°F (Indoor // Outdoor)	°F	70 DB, 60 WB // 47 DB, 43 WB
	³ Heating at 17°F (Indoor // Outdoor)	°F	70 DB, 60 WB // 17 DB, 15 WB
	Conditions	⁴ Heating at 5°F (Indoor // Outdoor)	°F
	⁶ Heating at -5°F (Indoor // Outdoor)	°F	70 DB, 60 WB // -5 DB, -6 WB
	⁷ Heating at -13°F (Indoor // Outdoor)	°F	70 DB, 60 WB // -13 DB, -14 WB

*Indoor/Outdoor Unit Operating Temperature Range (Cooling Air Temp [Maximum / Minimum]):

- Applications should be restricted to comfort cooling only; equipment cooling applications are not recommended for low ambient temperature conditions.

**Outdoor Unit Operating Temperature Range (Cooling Thermal Lock-out / Re-start Temperatures; Heating Thermal Lock-out / Re-start Temperatures):

- System cuts out in heating mode to avoid thermistor error and automatically restarts at these temperatures.

INDOOR UNIT ACCESSORIES: MSZ-FS18NA

Control Interface	BACnet® and Modbus® Interface	PAC-UKPRC001-CN-1
	CN24 Relay Kit	CN24RELAY-KIT-CM3
	IT Extender	PAC-WHS01IE-E
	kumo station® for kumo cloud®	PAC-WHS01HC-E
	Lockdown bracket for remote controller	RCMKP1CB
	System Control Interface	MAC-334IF-E
	Thermostat Interface	PAC-US444CN-1
	Thermostat Interface	PAC-US445CN-1
	USNAP Adapter	PAC-WHS01UP-E
	Wireless Interface for kumo cloud®	PAC-USWHS002-WF-2
Remote Sensor	Wireless temperature and humidity sensor for kumo cloud®	PAC-USWHS003-TH-1
Wired Remote Controller	Deluxe Wired MA Remote Controller†	PAR-40MAAU
	Simple MA Remote Controller†	PAC-YT53CRAU-J
	Touch MA Controller†	PAR-CT01MAU-SB
Wireless Remote Controller	kumo touch™ RedLINK™ Wireless Controller	MHK2
Condensate	Blue Diamond (Advanced) Mini Condensate Pump w/ Reservoir & Sensor (208/230V) [recommended]	X87-721
	Blue Diamond (MicroBlue) Mini Condensate Pump (110/208/230V) up to 18,000 BTU/H	X86-003
	Blue Diamond Alarm Extension Cable — 6.5 Ft.	C13-192
	Blue Diamond MultiTank — collection tank for use with multiple pumps	C21-014
	Blue Diamond Sensor Extension Cable — 15 Ft.	C13-103
	Drain Pan Level Sensor/Control	SS610E
	Fascia Kit for MicroBlue Pump, mounts the MicroBlue and sensor directly beneath indoor unit	T18-016
	Refco Condensate Pump (100-240 VAC)	GOBI-II
	Refco Condensate Pump (100-240 VAC) up to 120,000 BTU/H	COMBI
	Sauerermann Condensate Pump	SI30-230
Disconnect Switch	(30A/600V/UL) [fits 2" X 4" utility box] - Black	TAZ-MS303
	(30A/600V/UL) [fits 2" X 4" utility box] - White	TAZ-MS303W
Drain Hose	Flexible Mini-Split Drain Hose	DRX-16
Filter	Electro Static Anti-allergy Enzyme Filter	MAC-2330FT-E
	Platinum Deodorizing Filter	MAC-3000FT-E
Lineset	15' x 1/4" x 15' / 1/2" Lineset (Twin-Tube Insulation)	MLS141212T-15
	30' x 1/4" x 30' / 1/2" Lineset (Twin-Tube Insulation)	MLS141212T-30
	50' x 1/4" x 50' / 1/2" Lineset (Twin-Tube Insulation)	MLS141212T-50
	65' x 1/4" x 65' / 1/2" Lineset (Twin-Tube Insulation)	MLS141212T-65

NOTES:

†Requires MAC-334IF-E

- M-Series EZ FIT® Recessed Ceiling Cassette, Floor-mount and Wall-mount
 - Allows indoor units to connect to an MA Controller:
 - Deluxe MA Remote Controller
 - Simple MA Controller
 - Touch MA Controller

OUTDOOR UNIT ACCESSORIES: MUZ-FS18NA

Air Outlet Guide	Air Outlet Guide	MAC-890SG-E
Control/Service Tool	M- & P-Series Maintenance Tool Cable Set	M21EC0397
	USB/UART Conversion Cable (Required for all laptop connection)	M21EC1397
Drain Socket	Drain Socket	MAC-871DS
Hail Guards	Hail Guard	HG-A7
Mini-Split Wire	14 Gauge, 4 wire MiniSplit Cable—250 ft. roll	S144-250
	14 Gauge, 4 wire MiniSplit Cable—50 ft. roll	S144-50
	16 Gauge, 4 wire MiniSplit Cable—250 ft. roll	S164-250
	16 Gauge, 4 wire MiniSplit Cable—50 ft. roll	S164-50
Mounting Pad	Condensing Unit Mounting Pad: 16" x 36" x 3"	ULTRILITE1
	Outdoor Unit 3-1/4 inch Mounting Base (Pair) - Plastic	DSD-400P
Optional Defrost Heater	Base Heater	MAC-642BH-U1
Stand	18" Single Fan Stand	QSMS1801M
	24" Single Fan Stand	QSMS2401M
	Condenser Wall Bracket	QSWB2000M-1
	Condenser Wall Bracket - Stainless Steel Finish	QSWBSS
	Outdoor Unit Stand — 12" High	QSMS1201M

INDOOR UNIT DIMENSIONS: MSZ-FS18NA

Unit: inch

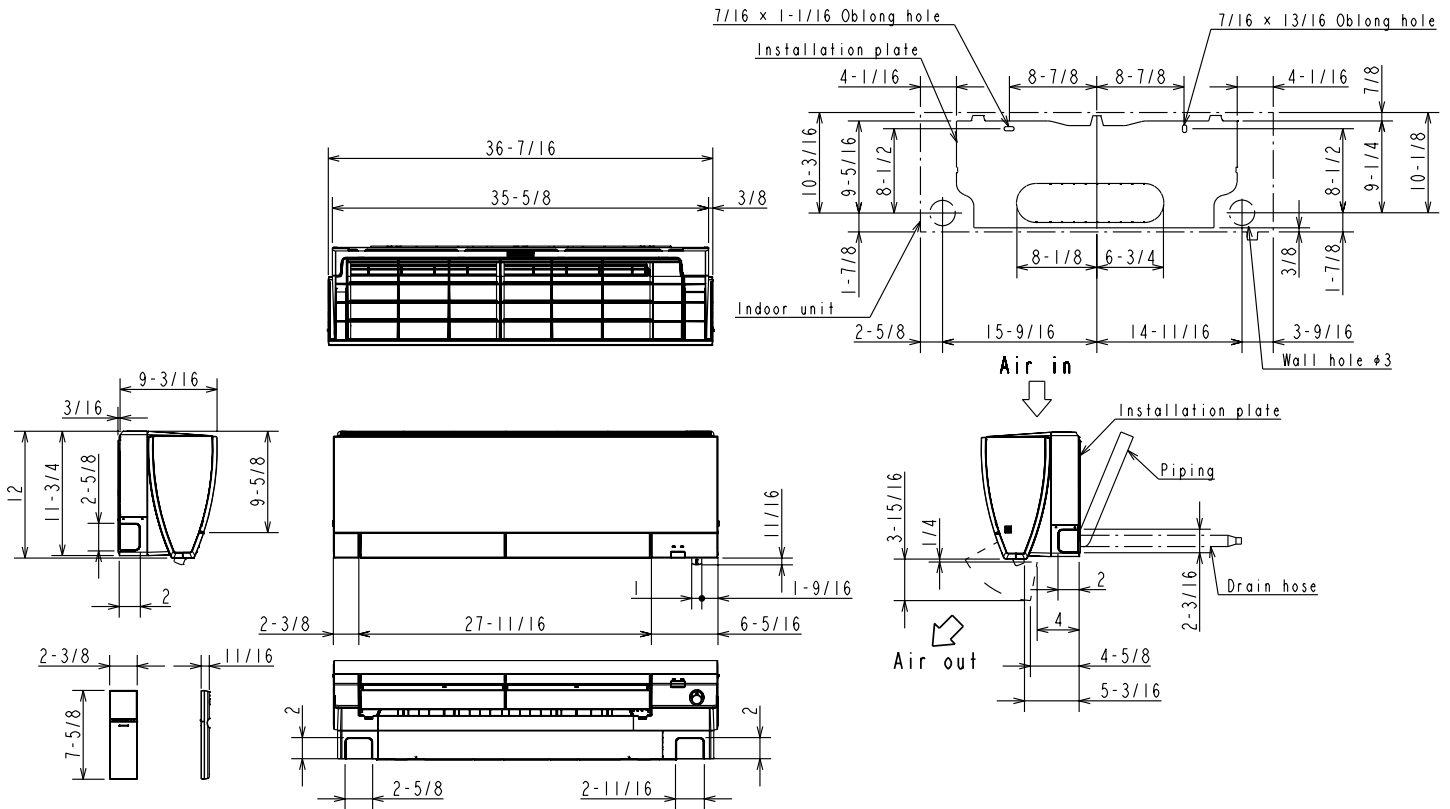

(06/09/12 KBTU/H)

Piping	Insulation	ø1-7/16 O.D
	Liquid line	ø1/4 19-11/16 (Flared connection ø1/4)
	Gas line	ø3/8 16-15/16 (Flared connection ø3/8)
Drain hose	Insulation	ø1-1/8 Connected part ø5/8 O.D

(15/18 KBTU/H)

Piping	Insulation	ø1-7/16 O.D
	Liquid line	ø1/4 19-11/16 (Flared connection ø1/4)
	Gas line	ø3/8 16-15/16 (Flared connection ø1/2)
Drain hose	Insulation	ø1-1/8 Connected part ø5/8 O.D

OUTDOOR UNIT DIMENSIONS: MUZ-FS18NA

Unit: inch

REQUIRED SPACE

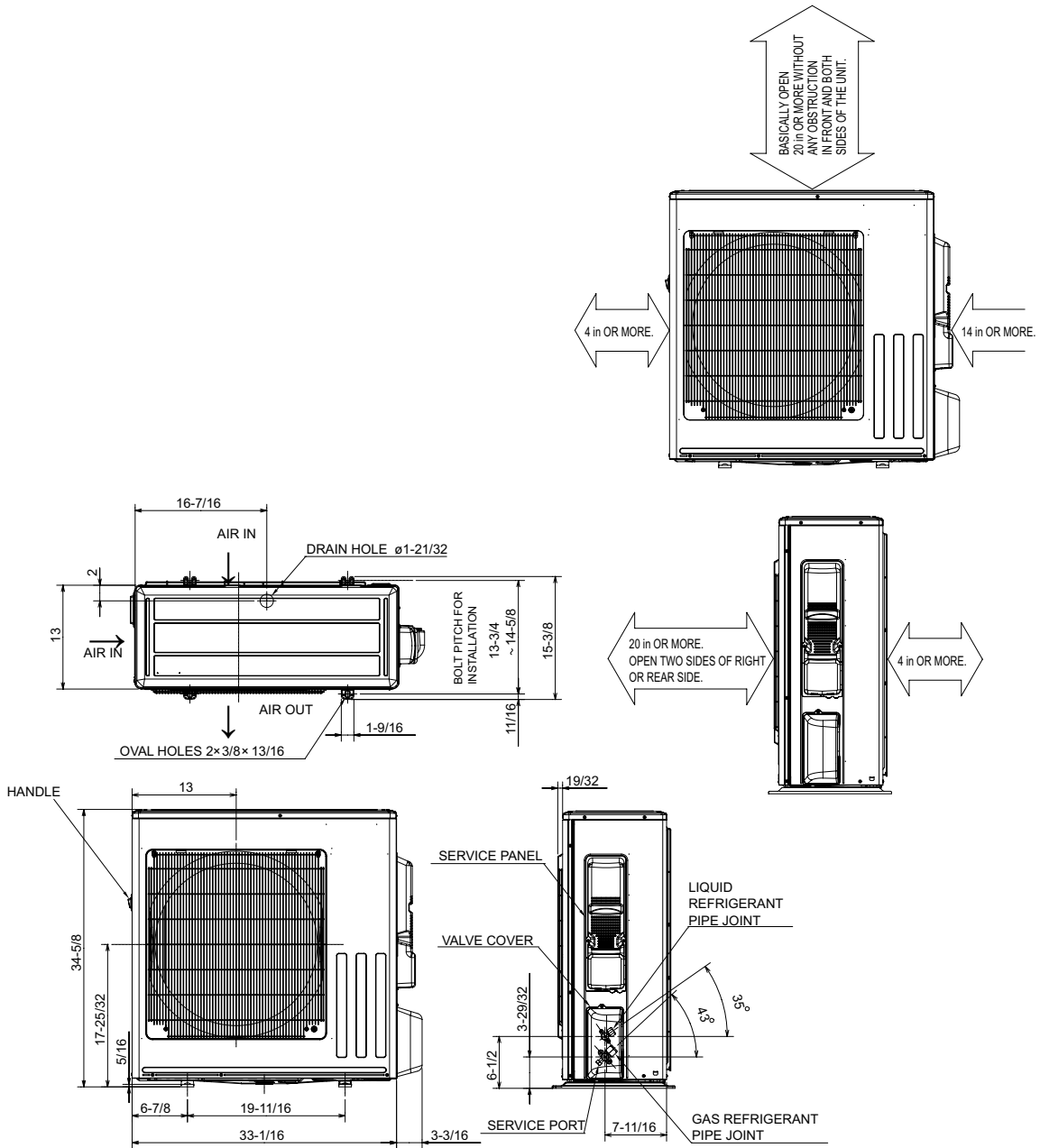

REFRIGERANT PIPE JOINT	LIQUID REFRIGERANT PIPE	FLARED $\phi 6.35 (1/4")$
	GAS REFRIGERANT PIPE	FLARED $\phi 12.7 (1/2")$

1340 Satellite Boulevard Suwanee, GA 30024
Toll Free: 800-433-4822 www.mehvac.com

FORM# MSZ-FS18NA & MUZ-FS18NA - 202211

